

33.910 Definitions

910

Sections:

- 33.910.010 Defining Words
- 33.910.020 Use of Terms
- 33.910.030 Definitions

33.910.010 Defining Words

Words used in the zoning code have their normal dictionary meaning unless they are listed in 33.910.030 below. Words listed in 33.910.030 have the specific meaning stated, unless the context clearly indicates another meaning.

33.910.020 Use of Terms

Information about the use of terms in the zoning code is contained in 33.700.070.D.

33.910.030 Definitions

The definition of words with specific meaning in the zoning code are as follows:

Accessible Route. A route that can be used by a disabled person using a wheelchair and that is also safe for and usable by people with other disabilities.

Accessory Dwelling Unit. See Residential Structure Types.

Accessory Parking Facility. A parking facility that provides parking for a specific use or uses. The facility may be located on or off the site of the use or uses to which it is accessory. A fee may or may not be charged. An accessory parking facility need not be in the same ownership as the specific uses to which it is accessory. See also Commercial Parking in Chapter 33.920, Descriptions of Use Categories.

Accessory Recreational Vehicle. See Recreational Vehicle, under Vehicle Types.

Accessory Structure. A structure of secondary importance or function on a site. In general, the primary use of the site is not carried on in an accessory structure. Accessory structures may be attached or detached from the primary structure. Examples of accessory structures include: garages, decks, fences, trellises, flag poles, stairways, heat pumps, awnings, and other structures. See also Primary Structure.

Accessory Use. A use or activity which is a subordinate part of a primary use and which is clearly incidental to a primary use on a site.

Adjusted Lot. See Lot-Related Definitions

Airport Airside Development. Airside development occurs at the Portland International Airport within the Perimeter Security Fence and the Runway Protection Zone. Examples include runways, taxiways, airfield roadways, aviation approach lighting systems, navigational beacons, associated equipment sheds, and security fencing.

Airport Landside Development. Landside development occurs at the Portland International Airport outside the Perimeter Security Fence. This area is comprised of the Passenger Terminal, airport access roadways, parking lots, aircraft maintenance facilities, cargo hangers, maintenance buildings, fire and rescue facilities, and other similar types of development.

Alley. A right-of-way that provides vehicle access to a lot or common parking area. Generally, alleys provide secondary vehicle access; however, where vehicle access from the street is not allowed or not possible, the alley may provide primary vehicle access. See also Street-Types.

Alteration. See Development, Alteration.

Alternative or Post Incarceration Facility. A Group Living use where the residents are on probation or parole.

Applicant. A person who applies for a land use review or building permit. An applicant can be the owner of the property or someone who is representing the owner, such as a builder, developer, optional purchaser, consultant, or architect.

Arborist. A professional listed as a certified arborist or a registered consulting arborist.

Arterial. See Street Types.

Attached Duplex. See Residential Structure Types.

Attached House. See Residential Structure Types.

Attached Structure. Any structure that is attached to a primary structure by a common wall or shares a common floor/ceiling. For example, a garage is an attached structure when it shares a common wall with a primary dwelling unit. Structures that are attached solely by elements other than a common wall or floor/ceiling are not considered attached. See Connected Structure.

Auto-Accommodating Development. See Development Types.

Aviation, General. General aviation refers to all flights other than military and scheduled airline and cargo flights, both private and commercial. Examples include business aviation, private flying, flight training, air ambulance, police aircraft, aerial firefighting, and air charter services.

Basement. The portion of a building that is partly or completely below grade. A minimum of 50 percent of the total combined area of the basement walls must be below grade to be considered a basement. Only one basement level may be partly below grade; additional basement levels must be completely below grade.

BDS. Bureau of Development Services.

Block. All of the property bounded by streets, rights-of-way, and water features, but is not divided or separated in any way by streets, rights-of-way, or water features.

Block Frontage. All of the property fronting on one side of a street that is between intersecting or intercepting streets, or that is between a street and a water feature, or end of a dead end street. An intercepting street determines only the boundary of the block frontage on the side of the street which it intercepts. See Figure 910-1.

**Figure 910-1
Block Frontage**

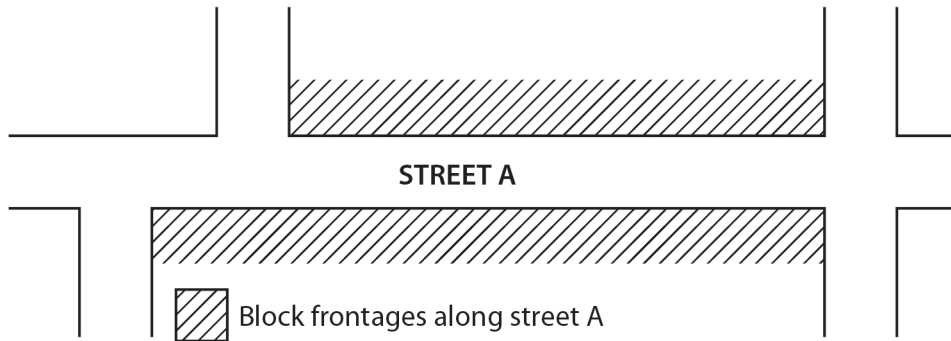

Building. A structure that has a roof and is enclosed on at least 50 percent of the area of its sides.

Building Coverage. The area that is covered by buildings or other roofed structures. A roofed structure includes any structure more than 6 feet above grade at any point, and that provides an impervious cover over what is below. Building coverage also includes uncovered horizontal structures such as decks, stairways and entry bridges that are more than 6 feet above grade. Eaves that are 2 feet or less in depth are not included in building coverage. Eaves that are greater than 2 feet in depth are included in building coverage.

Building Line. A line running parallel to a lot line, that is the same distance from the lot line as the closest portion of a building on the site. See Figure 910-2.

**Figure 910-2
Building Lines**

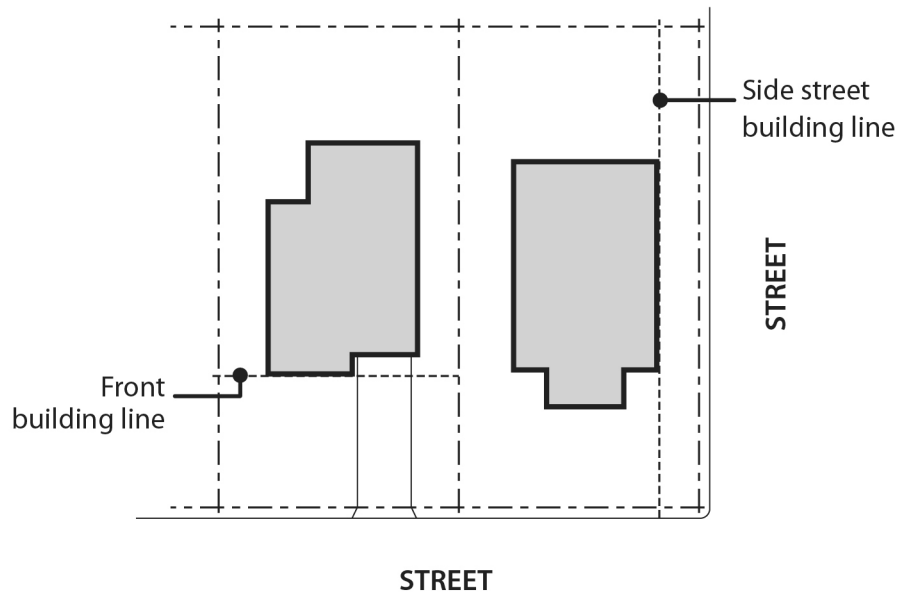

Bus Stop. A location where regularly scheduled bus service or streetcar service stops to load and unload passengers. For purposes of measuring, the bus stop is the location of a sign denoting the bus stop.

Calendar Year is the year from January 1 through December 31.

Caretaker. A caretaker looks after or provides security for goods or property.

Carpool. At least two people sharing a vehicle at least four days per week, generally for the purpose of commuting to work.

Cemetery. An open space site for burial, entombment, inurnment, interment, cremation, or funeral purposes.

Certificate of Occupancy. A certificate of occupancy or a certificate of inspection issued by BDS at the completion of a building permit or change of occupancy.

Change of Use. Change of the primary type of activity on a site. For example, in the Retail Sales and Service use category, a change from a restaurant to a bank would be considered a change in the primary type of activity; a change from a restaurant to a restaurant would not be considered a change in the primary type of activity.

City. The City of Portland, Oregon.

City-Designated Natural Resources. Natural resources and functional values protected by Environmental Overlay Zones.

Clearing. Any activity that removes existing vegetation or strips surface material from any portion of the site.

Combined Flood Hazard Area. The farthest extent of the land area comprised of the Special Flood Hazard Area, the Modeled Willamette River 1996 Flood Extent and, for areas not included in the Modeled Willamette River 1996 Flood Extent, the 1996 Flood Inundation Area.

Common Green. See Street Types.

Community Garden. A site where any kind of plant, including flowers, is grown, and several individuals or households cultivate the site. The site may be divided into individual allotments, or gardeners may work together to cultivate the entire property. The land may be publicly or privately owned. The plants are grown for personal use by the gardeners, or for donation, and only limited sales are allowed.

Comprehensive Plan. The current adopted, acknowledged, and effective Comprehensive Plan of the City of Portland.

Congregate Housing Facility. See Residential Structure Types.

Connected Structure. Any structure that is connected to a primary structure by a roof, a deck or by other structural connections, and which does not share a common wall, ceiling or floor. For example, decks or stairways are connected structures when they are fastened to a primary structure. A garage that is connected to a primary structure by a roofed structure such as a breezeway, and does not share a common wall with the primary structure, is a connected accessory structure. See Attached Structure.

Convenience Store. Any retail grocery store that has all of the following characteristics:

- Is under 4,000 square feet in area;
- Requires a package store liquor license; and
- Is open more than 15 hours a day.

Conservation Landmark. See Historic Resource.

Contributing Resource. See Historic Resource.

Corner Lot. See Lot-Related Definitions.

Courtyard. An outdoor area, designed for use by pedestrians, surrounded on at least two sides by buildings and open on at least one side to an abutting right-of-way.

Council. The City Council of Portland, Oregon.

Crown Cover. The area directly beneath the crown and within the dripline of a tree or shrub. The crown consists of the above ground branches, stems, and leaves.

Days. Calendar days, unless specifically stated as working days. Working days include Monday through Friday, excluding holidays as identified in Section 4.16.080 of Title 4, Personnel.

Delivery Days. Days when deliveries of food or other goods are made to Food Membership Distribution Sites for later pick-up by members of Food Buying Clubs or Community Supported Agriculture Organizations.

Dead-End Street. See Street Types.

Density. A measurement of the number of people, dwelling units, or lots in relationship to a specified amount of land. Density is a measurement used generally for residential uses. See Chapter 33.205, Accessory Dwelling Units for how density is calculated for ADUs. See also Intensity.

Design Guidelines. A set of design parameters for development which apply within a design district, subdistrict, or overlay zone. The guidelines are adopted public statements of intent and are used to evaluate the acceptability of a project's design.

Desired Character. The preferred and envisioned character (usually of an area) based on the purpose statement or character statement of the base zone, overlay zone, or plan district. It also includes the preferred and envisioned character based on any adopted area plans or design guidelines for an area.

Develop. To construct or alter a structure or to make a physical change to the land including excavations and fills.

Developed Portion of Right-of-way. Those portions of a right-of-way that contain development, including retaining walls or other structures, vehicle travel lanes, parking and loading areas, curbs, landscape strips, sidewalks, shoulders, other paved or graveled areas, and other areas used for bicycle or pedestrian traffic. It does not include natural geologic forms or unimproved land.

Development. All improvements on a site, including buildings, other structures, parking and loading areas, landscaping, paved or graveled areas, and areas devoted to exterior display, storage, or activities. Development includes improved open areas such as plazas and walkways, but does not include natural geologic forms or unimproved land. See also Exterior Improvements.

Development, Alteration. A physical change to a structure or site. Alteration does not include normal maintenance and repair or total demolition. Alteration does include the following:

- Changes to the facade of a building;
- Changes to the interior of a building;
- Increases or decreases in gross building area;
- Changes to other structures on the site, or the development of new structures;

- Changes to exterior improvements;
- Changes to landscaping; and
- Changes in the topography of the site.

Development, Exterior Alteration. A physical change to a site that is outside of any buildings. Exterior alteration does not include normal maintenance and repair or total demolition. Exterior alteration does include the following:

- Changes to the facade of a building;
- Increases or decreases in gross building area that result in changes to the exterior of a building;
- Changes to other structures on the site or the development of new structures;
- Changes to exterior improvements;
- Changes to landscaping; and
- Changes in the topography of the site.

Development, New. Development of a site that was previously unimproved or that has had previously existing buildings demolished.

Development Types

- **Auto-Accommodating Development.** Development which is designed to accommodate customers who use autos to travel to the site. Buildings feature entrances providing convenient access to parking areas. In many cases, the building will have parking between secondary streets and the building. Other typical characteristics are drive-through facilities, more than one driveway, and a low percentage of the site covered by buildings. Auto-accommodating development along transit streets and in pedestrian districts typically include a mix of auto-accommodating and pedestrian-oriented characteristics. See also Pedestrian-Oriented Development.
- **Pedestrian-Oriented Development.** Development which is designed with an emphasis primarily on the street sidewalk and on pedestrian access to the site and building, rather than on auto access and parking areas. The building is generally placed close to the street and the main entrance is oriented to the street sidewalk. There are generally windows or display cases along building facades which face the street. Typically, buildings cover a large portion of the site. Although parking areas may be provided, they are generally limited in size and they are not emphasized by the design of the site. See also Auto-Accommodating Development.

Director of BDS. The Director of the City of Portland Bureau of Development Services, or the Director's designee.

Disabled Person. For the purposes of Chapter 33.229, Elderly and Disabled High Density Housing, a disabled person is a person who has a condition of physical or mental disability which substantially limits one or more major life activities as stated in Section 504 of the Federal Rehabilitation Act of 1973 and state law.

Disturbance. An action that causes an alteration to soil or vegetation. The action may create temporary or permanent disturbance. Examples include development, exterior alterations, exterior

improvements, demolition and removal of structures and paved areas, cutting, clearing, damaging, or removing native vegetation.

Disturbance Area. The area where all temporary and permanent disturbance occurs. For new development the disturbance area must be contiguous. Native vegetation planted for resource enhancement, mitigation, remediation, and agricultural and pasture lands is not included. The disturbance area may contain two subareas, the permanent disturbance area and the temporary disturbance area:

- **Permanent Disturbance Area.** The permanent disturbance area includes all areas occupied by existing or proposed structures or exterior improvements. The permanent disturbance area also includes areas where vegetation must be managed to accommodate overhead utilities, existing or proposed non-native planting areas, and roadside areas subject to regular vegetation management to maintain safe visual or vehicle clearance.
- **Temporary Disturbance Area.** The temporary disturbance area is the portion of the site to be disturbed for the proposed development but that will not be permanently occupied by structures or exterior improvements. It includes staging and storage areas used during construction and all areas graded to facilitate proposed development on the site, but that will not be covered by permanent development. It also includes areas disturbed during construction to place underground utilities, where the land above the utility will not otherwise be occupied by structures or exterior improvements.

Drainageway. A constructed or natural channel or depression, which at any time collects and conveys water. It may be permanently or temporarily inundated.

Drive-Through Facility. A facility or structure that is designed to allow drivers to remain in their vehicles before and during an activity on the site. Drive-through facilities are a type of site development that is usually found in conjunction with a Quick Vehicle Servicing use or a Retail Sales And Service use. Drive-through facilities also include facilities designed for the rapid servicing of vehicles, where the drivers may or may not remain in their vehicles, but where the drivers usually either perform the service for themselves, or wait on the site for the service to be rendered. Drive-through facilities may serve the primary use of the site or may serve accessory uses. Examples are drive-up windows; menu boards; order boards or boxes; gas pump and electric vehicle charging islands; car wash facilities; auto service facilities, such as air compressor, water, and windshield washing stations; quick-lube or quick-oil change facilities; and drive-in theaters. Parking spaces used for customer pick-up or loading of goods or products purchased on-site, on the phone, or on-line from the establishment are not a drive-through facility. . Parking spaces that include electric vehicle chargers and equipment are not a drive-through facility. Facilities designed for electric vehicle charging or the picking-up or loading of goods or products purchased from the establishment that include a stacking lane and a service area are a drive-through facility.

Driveway. There are two types of driveways:

- The area that provides vehicular access to a site. A driveway begins at the property line and extends into the site. A driveway does not include parking, maneuvering, or circulation areas in parking areas, such as aisles; and
- The area that provides vehicular circulation between two or more noncontiguous parking areas. A driveway does not include maneuvering or circulation areas within the interior of a parking area. A driveway must be used exclusively for circulation, with no abutting parking spaces. See Figure 910-13.

See also Parking Area and Vehicle Areas.

Figure 910-13
Driveway

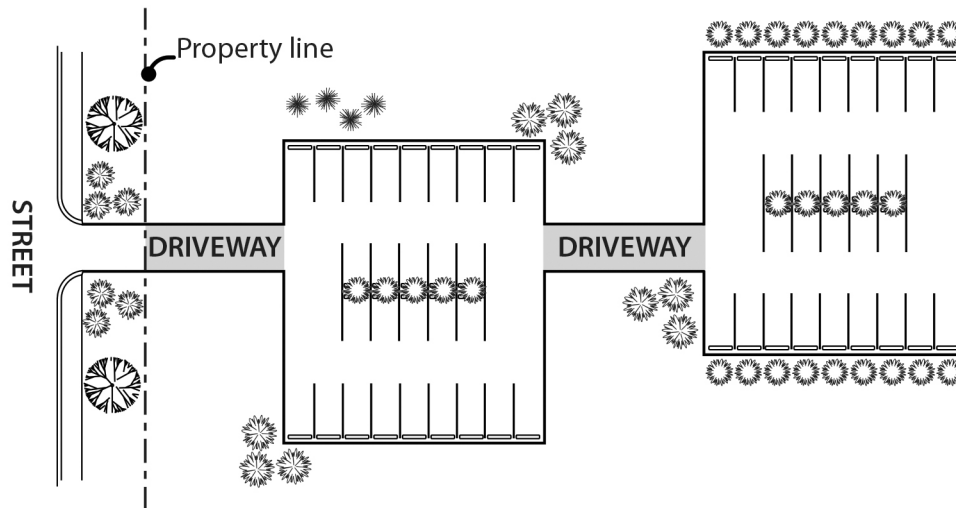

Duplex. See Residential Structure Types.

Dwelling Unit. See Residential Structure Types.

Easement. A grant of rights by a property owner that allows others to use the owner's land for a specific purpose, such as access, or to locate utilities.

Eave. Projecting overhang at the lower border of a roof and extending from a primary wall or support. See Figure 910-14.

Figure 910-14
Eave



Ecologically and Scientifically Significant Natural Areas. Land and water that has substantially retained its natural character, but is not necessarily completely natural or undisturbed, and which is significant for historical, scientific, paleontological, or natural features.

ESEE Analysis. A type of analysis which is used to help determine if a particular resource should be protected in accordance with Statewide Planning Goal 5. The analysis examines competing values to determine what the controlling value should be for the individual resource being examined. The analysis considers economic, social, energy, and environmental values.

Excavating or Filling. The removal, placement, or replacement of earth, concrete, asphalt, and similar nondecomposable materials whether permanent or temporary in nature. Excavating or filling does not include the movement of earth or placement of gravel, asphalt, or other paving materials that is done in conjunction with road improvements. It does not include the excavation of mineral or aggregate resources. Excavating or filling includes the terms grading, preloading, surcharging, and stockpiling.

Exchange Parcel. The area of land to be conveyed from one property to another through a Property Line Adjustment. A single Property Line Adjustment may involve more than one exchange parcel. See Property Line Adjustment.

Expedited Land Division. An Expedited Land Division is a division of land under ORS 92.010 (Definitions for ORS 92.010 to 92.192) to 92.192 (Property line adjustment), 92.205 (Policy) to 92.245 (Fees for review proceedings resulting in modification or vacation) or 92.830 (Definitions for ORS 92.830 to 92.845) to 92.845 (Relationship of subdivision in manufactured dwelling park or mobile home park to planned community statutes and series partition statutes) by a local government that, unless it is a middle housing land division, meets all of the elements of ORS 197.360.

Exterior Alteration. See Development, Exterior Alteration.

Exterior Display. Exterior display includes the outdoor display of products, vehicles, equipment, and machinery for sale or lease. Exterior display is an outdoor showroom for customers to examine and compare products. There is variety or a distinction among the goods on display, through different products, brands, or models. The display area does not have to be visible to the street. Exterior display does not include goods that are being stored or parked outside, if there is no variety or distinction among the goods, and the goods are not examined and compared by customers. It does not include damaged or inoperable vehicles, vehicles or equipment being serviced, bulk goods and materials, and other similar products. Exterior display does not include car and boat sales and leasing when such vehicles are not accessible to customers to inspect and compare; this situation is considered exterior storage. Examples of uses that often have exterior display are car and boat sales and leasing, and plant nurseries. See also, Exterior Work Activities and Exterior Storage.

Exterior Improvements. All improvements except buildings or other roofed structures. Exterior improvements include surface parking and loading areas, paved and graveled areas, and areas devoted to exterior display, storage, or activities. It includes improved open areas such as plazas and walkways, but does not include vegetative landscaping, synthetic turf, natural geologic forms, or unimproved land. See also Development.

Exterior Storage. Exterior storage includes the outdoor storage of goods that generally have little or no differentiation by type or model. The goods may be for sale or lease, but if so, they are the type that customers generally do not inspect and compare. Exterior storage also includes the outdoor storage of goods for sale, lease or rent that may be differentiated by type or model, but that are not accessible for customers to inspect or compare. Exterior storage includes the storage of raw or finished goods (packaged or bulk), including gases, oil, chemicals, gravel; building materials, packing materials; salvage goods; machinery, tools, and equipment; vehicles that are for sale, lease or rent, which are not accessible to the customer to inspect or compare; vehicles that have been unloaded

at port facilities and are waiting transport to off-site locations; vehicles that have been towed and are being kept in an impound lot; and other similar items. The storage of recreational vehicles outdoors is also considered exterior storage. Damaged or inoperable vehicles or vehicles which have missing parts, that are kept outside, are also included as exterior storage. Examples of uses that often have exterior storage are lumber yards, wrecking yards, tool and equipment rental, bark chip and gravel sales, car dealerships or car rental establishments, and port facilities. If goods are stored inside a building that is not enclosed on 100 percent of the area of its sides, it is considered exterior storage. See also, Exterior Display and Exterior Work Activities.

Exterior Work Activities. Exterior work activities include the outdoor processing, assembly, or fabrication of goods; the maintenance, repair, and salvage of vehicles and equipment; and other similar activities that generally have an industrial orientation. Exterior work activities do not include normal pick-up and deliveries to a site, parking, excavation and fills, exterior eating areas, outdoor recreation, or outdoor markets. See Exterior Display and Exterior Storage.

Facade. All the wall planes of a structure as seen from one side or view. For example, the front facade of a building would include all of the wall area that would be shown on the front elevation of the building plans. For information on how to measure facades, see Chapter 33.930, Measurements.

Farmers Market. Farmers Markets are events where farmers, ranchers, and other agricultural producers sell food, plants, flowers, and added-value products, such as jams and jellies, they have grown, raised, or produced from products they have grown or raised. In addition, some vendors sell food that is available for immediate consumption on site, and some may be community groups, services, or other vendors or organizations. Farmers Markets occur on a regular basis in the same location. They are free and open to the public. Some markets are seasonal, while others occur year-round.

Final Plat. The diagrams, drawings, and other writing containing all the descriptions, locations, dedications, provisions and information concerning a land division.

Fish and Wildlife Habitat Areas. Lands which contain significant food, water, or cover for native terrestrial and aquatic species of animals. Examples include forests, fields, riparian areas, wetlands, and water bodies.

Flag Lot. See Lot-Related Definitions.

Floodway. The active flowing channel during a flood, as designated on the flood maps adopted under authority of Title 24 of the Portland City Code. The channel of a river or other watercourse and the adjacent land areas that must be reserved in order to discharge the base flood without cumulatively increasing the water surface elevation more than a designated height.

Floor Area. The total area of all floors of a building. Floor area is measured for each floor from the exterior faces of a building or structure. Floor area includes stairwells, ramps, shafts, chases, and the area devoted to garages and structured parking. Floor area does not include the following:

- Areas where the elevation of the floor is 4 feet or more below the adjacent right-of way;
- Basements;
- Areas where the ceiling height is less than 6 feet 8 inches. See Figure 910-20;
- Roof area, including roof top parking;
- Roof top mechanical equipment; and

- Roofed porches, exterior balconies, or other similar areas, unless they are enclosed by walls that are more than 42 inches in height for 75 percent or more of their perimeter.

See also Net Building Area, Gross Building Area

Figure 910-20
Ceiling Height

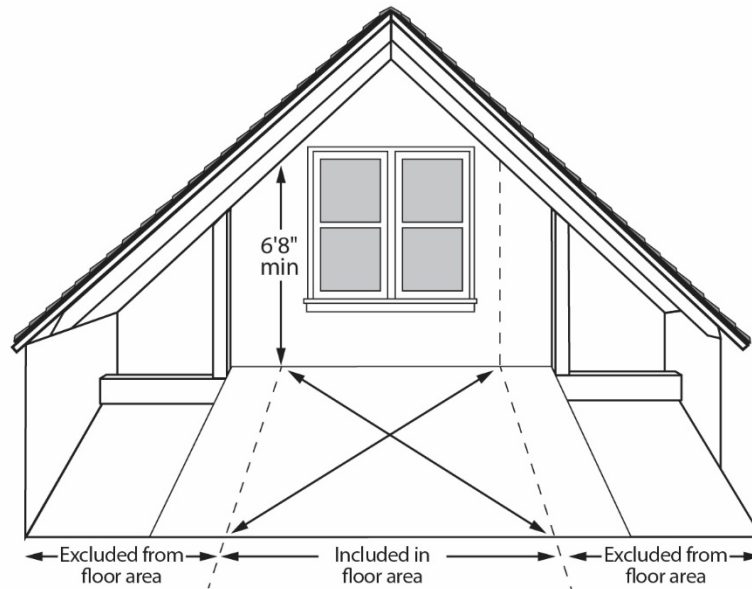

Floor Area Ratio (FAR). The amount of floor area in relation to the amount of site area, expressed in square feet. For example, a floor area ratio of 2 to 1 means two square feet of floor area for every one square foot of site area.

Food Membership Distribution Site. A site where items ordered through the following organizations are picked up by the members.

- **Food Buying Clubs** are membership organizations. The members, as a group, buy food and related products from wholesalers, distributors, growers, and others. All products are pre-ordered and pre-paid, and at least 70 percent of the products are food.
- **Community Supported Agriculture Organizations** are membership organizations. Individuals or households become members by purchasing a share or a specified amount of an agricultural producer's output in advance. Members receive food items from the producer on a regular schedule.

Fossil Fuel. Fossil fuels are petroleum products (such as crude oil and gasoline), coal, methanol, and gaseous fuels (such as natural gas and propane) that are made from decayed plants and animals that lived millions of years ago and are used as a source of energy. Petroleum-based products used primarily for non-fuel uses (such as asphalt, plastics, lubricants, fertilizer, roofing, and paints) are not fossil fuels. See Renewable Fuel.

Front Lot Line. See Lot Lines.

Front Setback. See Setback.

Functional Values. Functional values are the benefits provided by resources. The functional value may be physical, aesthetic, scenic, educational, or some other nonphysical function, or a combination of these. For example, two values of a wetland could be its ability to provide stormwater detention for x units of water draining y acres, and its ability to provide food and shelter for z varieties of migrating waterfowl. As another example, an unusual native species of plant in a natural resource area could be of educational, heritage, and scientific value. Most natural resources have many functional values.

Future Division Plan. A document that shows lot, tract and right-of-way boundaries for all future phases of a land division. The plan is not binding on the City or the applicant. The purpose of the plan is to document that the design of the first phase of the plan does not preclude future phases from meeting the requirements of this and other Titles.

Garage. A covered structure that is accessory to a use in a house, attached house, duplex, triplex, fourplex, cottage cluster, manufactured dwelling, or houseboat, and that:

- Is designed to provide shelter for vehicles;
- Is connected to a right-of-way by a driveway; and
- Has an opening that is at least 8-feet wide.

Carports are considered garages. Floor area adjacent to the space designed to provide shelter for vehicles, if not entirely separated from the garage area by floor-to-ceiling walls, is considered part of the garage. A garage may be attached to or detached from another structure. See also Structured Parking.

Garage Entrance Setback. See Setback.

Grade. The final elevation of the ground.

Grading. All cuts, fills, embankments, stockpile areas, and equipment maneuvering areas associated with development.

Gross Building Area. The total area of all floors of a building, both above and below ground. Gross building area is measured from the exterior faces of a building or structure. Gross building area includes structured parking but does not include the following:

- Roof area;
- Roof top mechanical equipment; and
- Roofed porches, exterior balconies, or other similar areas, unless they are enclosed by walls that are more than 42 inches in height, for 75 percent or more of their perimeter.

Groundwater Sensitive Areas. Areas from which groundwater is replenished and the flow enables contaminants to be carried into aquifers (aquifer recharge areas), or areas of an aquifer in which the groundwater level and flow characteristics are influenced by the withdrawal of groundwater (areas of influence).

Hazardous Substances. Any substance, material, or waste listed below:

- Nuclear or radioactive materials or waste;
- Chemicals listed in the List of Lists: Chemicals Subject to the Emergency Planning and Community Right-To-Know Act (EPCRA), Comprehensive Environmental Response, Compensation and Liability Act (CERCLA) and Section 112(r) of the Clean Air Act, published

March 15, 2015, U.S. Environmental Protection Agency, or as subsequently updated or amended; and

- Hazardous Materials Table, in the Code of Federal Regulations (CFR), Title 49, Part 172.101, or as subsequently updated or amended.

Heavy Truck. See Truck under Vehicle Types.

Helicopter Approach-Departure Flight Path. The approved route used by helicopters when approaching or departing from a helicopter landing facility. In general, the helicopter approach-departure flight path has dimensions as follows: 1) It is a trapezoid-shaped plane; 2) its inner width is the same as the width of the landing pad and its outer width is 500 feet at a distance of 4,000 feet from the landing pad; and 3) it has a slope of 1 (vertical) to 8 (horizontal). See Figure 910-3. See also, FAA Heliport Design Guide for more detailed flight path standards and requirements.

Figure 910-3
Helicopter Approach-Departure Flight Paths

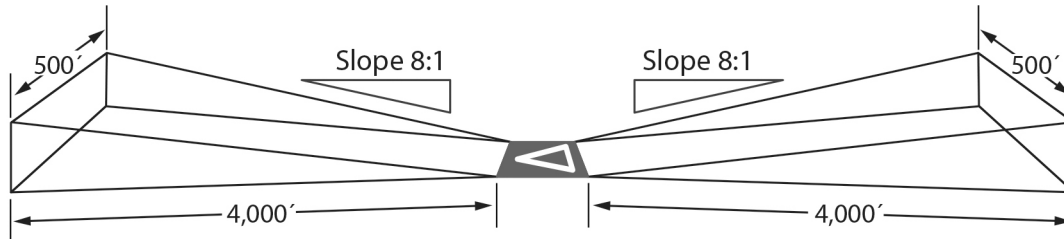

Helicopter Landing Facility (HLF). Any area used for the landing and take off of helicopters including heliports, helipads, and helistops. Peripheral areas, hangars, parking pads, passenger terminals, and helicopter service areas are also part of such facilities.

- **Private Helicopter Landing Facility.** A helicopter landing facility which is restricted to use by the owner or by persons authorized by the owner. Such facilities cannot be used by the general public and are restricted to specific users and purposes.
- **Public Helicopter Landing Facility.** A helicopter landing facility which is open to use by the general public, and where helicopter landings do not require prior permission of the owner. It may be owned by a public agency, an individual, or other legal entity as long as it is open for public use.

Helicopter Trip. Each landing or take-off of a helicopter. A landing and a take-off is counted as two trips.

Heritage Tree. See Tree Types.

Historic Landmark. See Historic Resource.

Historic Landmark Tree. A tree designated by the Historic Landmarks Commission because of its historical or cultural significance.

Historic Resource. A building, portion of a building, structure, object, landscape, tree, site, place, or district that has a significant relationship to events or conditions of the human past. Historic Resources may be important for archaeological, architectural, cultural, or historical reasons. Historic Resources include:

- **Historic Landmark.** A Historic Landmark is a building, portion of a building, structure, object, landscape, tree, site, or place that has been designated for its special archaeological, architectural, cultural, or historical merit. Historic Landmark includes structures, objects, and sites listed by the federal Keeper of the National Register of Historic Places on or before January 27, 2017, that have not had their Historic Landmark designation removed. Information supporting a specific Historic Landmark's significance and integrity is found in its National Register nomination or the documentation done in support of the City designation. Historic Landmarks have boundaries that are described in the nomination or documentation provided in support of the resource's City designation or National Register listing. If no boundary is provided in the designation or listing documentation, the boundary is the site or sites that contain the Historic Landmark's contributing resources;
- **Conservation Landmark.** A Conservation Landmark is a building, portion of a building, structure, object, landscape, tree, site, or place that the City has designated for its special archaeological, architectural, cultural, or historical merit. Information supporting a specific Conservation Landmark's significance and integrity is found in the documentation done in support of the City designation. Conservation Landmarks have boundaries that are described in the documentation provided in support of the resource's City designation. If no boundary is provided in the designation or listing documentation, the boundary is the site or sites that contain the Conservation Landmark's contributing resources;
- **National Register Landmark.** A National Register Landmark is a building, structure, object, or site that has been listed by the federal Keeper of the National Register of Historic Places and has not been designated or identified by the City as a Historic Landmark or Conservation Landmark. National Register Landmark includes resources listed by the federal Keeper of the National Register of Historic Places after January 27, 2017, that have not been designated by the City as a Historic Landmark or Conservation Landmark and resources that were listed by the federal Keeper of the National Register of Historic Places on or before January 27, 2017 that have had their Historic Landmark or Conservation Landmark designation removed. Information supporting a specific National Register Landmark's significance and integrity is found in its National Register nomination. National Register Landmarks have boundaries that are described in the nomination provided in support of the federal listing;
- **Historic District.** A Historic District is a geographic area that has been designated for its archaeological, architectural, cultural, or historical merit. Historic District includes districts listed by the federal Keeper of the National Register of Historic Places on or before January 27, 2017, that have not had their Historic District designation removed. Information supporting a specific Historic District's significance and integrity is found in its National Register nomination or the documentation done in support of the City designation. Historic Districts have boundaries that are described in the nomination or documentation provided in support of the resource's City designation or National Register listing;
- **Conservation District.** A Conservation District is a geographic area that the City has designated for its special archaeological, architectural, cultural, or historical merit. Information supporting a specific Conservation District's significance and integrity is found in the documentation done in support of the City designation. Conservation Districts have boundaries that are described in the documentation provided in support of the resource's City designation;
- **National Register District.** A National Register District is a district that has been listed by the federal Keeper of the National Register of Historic and has not been designated or identified by the City as a Historic District or Conservation District. National Register District includes

resources listed by the federal Keeper of the National Register of Historic Places after January 27, 2017, that have not been designated by the City as a Historic District or Conservation District and resources that were listed by the federal Keeper of the National Register of Historic Places on or before January 27, 2017 that have had their Historic District or Conservation District designation removed. Information supporting a specific National Register District's significance and integrity is found in its National Register nomination. National Register Districts have boundaries that are described in the nomination provided in support of the federal listing;

- **Significant Resource.** A Significant Resource is a building, portion of a building, structure, object, landscape, tree, site, or place that the City has determined to be significant for its archaeological, architectural, cultural, or historical merit but has not been designated by the City as a landmark or district, and has not been listed by the federal Keeper of the National Register of Historic Places. Rank I, II, III resources identified in the 1984 Historic Resource Inventory that have not been demolished or removed are Significant Resources; and
- **Contributing Resource.** A contributing resource is a building, portion of a building, structure, object, landscape, tree, site, or place that adds to the archeological value, architectural qualities, cultural significance, or historic associations, that make a Historic Landmark, Conservation Landmark, National Register Landmark, Historic District, Conservation District, National Register District, or Significant Resource important, as identified in the documentation prepared for the City designation, National Register listing, or City Significant Resource identification. If a resource is not identified or described in the documentation as contributing to the historic significance of the landmark, district, or Significant Resource, it is a noncontributing resource.

Historic Resources Inventory. Buildings, portions of buildings, structures, objects, landscapes, trees, sites, places, and districts that have been documented as having or potentially having archaeological, architectural, cultural, or historical significance. The Historic Resource Inventory includes all resources defined as Historic Resources. See Historic Resource.

Historic Restoration. Actions undertaken to accurately depict the form, features, and character of a historic resource as it appeared at a particular period of time. This is done by removing features not from that particular period, and reconstructing missing features from that particular period.

Historic Value. A physical, aesthetic, scenic, educational, or other characteristic which is a reminder of important events or developments in Portland's past.

Home Occupation. A business activity that is carried out on the same site as a dwelling unit, and which is accessory to the Household Living use on the site.

House. See Residential Structure Types.

Houseboat Moorage. See Residential Structure Types.

Identified Wetlands, Identified Streams Identified Waterbodies. Those streams, wetlands, and waterbodies that are identified in the resource inventory or maps as being significant and in need of protection.

Institutional Campus. A medical or educational institution and associated uses, on a site at least 5 acres in area. Medical institutional campuses include medical centers and hospitals. Educational institutional campuses include universities, colleges, high schools, and other similar institutions offering course of study leading to a high school diploma or degree certified by a recognized

accreditation body. Associated uses on institutional campuses may include some commercial and light industrial uses, major event entertainment, residential, and other uses.

Intensity. The amount or magnitude of a use on a site or allowed in a zone. Generally, it is measured by floor area. It may also be measured by such things as number of employees, amount of production, trip generation, or hours of operation. See also Density.

Kennel. Any location where 5 or more dogs or cats aged 6 months or older are boarded or bred. The sale of these animals may be a part of the kennel use. Establishments where animals are offered for sale as the primary use, such as pet stores, are not classified as kennels.

Land Division. The act of dividing land to create new lots or tracts, or to reconfigure lots or tracts within a recorded land division. The result of a land division is a subdivision plat or partition plat. Actions that are exempt from the State law definitions of partition or subdivision (i.e., property line adjustment) are not considered land divisions. See also, Expedited Land Division, Lot, Tract, Plat, and Property Line Adjustment.

Land Use Approval. A land use decision for approval or approval with conditions. It includes any time limits or other restrictions that may apply to the land use decision.

Ldn (or DNL). An averaged sound level measurement, taken during a 24 hour period, with a weighting applied to night time sound levels. The Ldn noise contours described in Chapter 33.470, Portland International Airport Noise Impact Zone, are based on Ldn levels that have been averaged over the period of a year.

Light Rail Line. A public rail transit line that usually operates at grade level and that provides high capacity, regional level transit service. A light rail line is designed to share a street right-of-way although it may also use a separate right-of-way or easement. Existing and future light rail lines are designated on the Regional Transitways Map in the Transportation Element of the Comprehensive Plan. Low capacity, district level, or excursion rail transit service, such as a streetcar, is not included.

Light Rail Alignment. A public right-of-way or easement that has a light rail line in it, or that has been designated as a preferred alternative light rail alignment. A Preferred Alternative Light Rail Alignment is a public right-of-way or easement designated by City Council and the regional transit agency as a future light rail alignment after completion of a Draft Environmental Impact Statement (DEIS).

Light Truck. See Truck under Vehicle Types.

Live Stake. A live, rootable vegetative cutting that is driven into the ground. Live stakes can be integrated into rock (riprap), slopes, or used with bioengineering methods to stabilize slopes.

Living Area. The total gross building area of a residential structure excluding the following:

- garage area;
- basement area where the floor to ceiling height is less than 6 feet 8 inches;
- attic area, and other building area, that is not accessible by a stairway or where the floor to ceiling height is less than 5 feet; and
- area between the outside of exterior walls and the inside of those walls. See Figure 910-15.

Figure 910-15
Calculation of Living Area

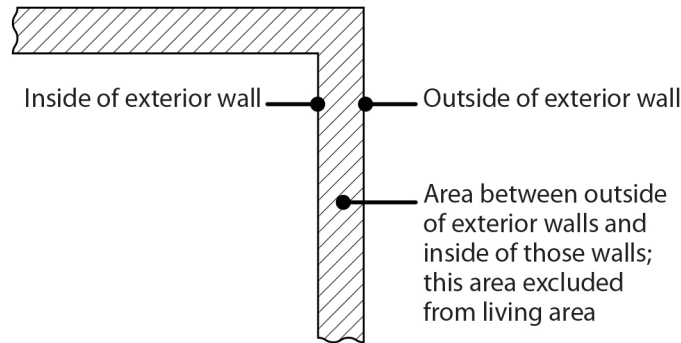

Loading Area. The area available for the maneuvering and standing of vehicles engaged in delivering and loading of passengers, freight, or other articles.

Long-Term Bicycle Parking. Long-term bicycle parking serves employees, students, residents, commuters, and others who generally stay at a site for several hours or more. See also Short-Term Bicycle Parking.

Long Term Parking. Parking having a duration of more than four hours.

Longest Street-Facing Wall. The longest wall that faces a street. If two or more street-facing walls are of equal length, and are the longest that face the street, then the applicant chooses which is to be the longest street-facing wall for purposes of applying regulations of this Title. See also, Façade, and Chapter 33.930, Measurements.

Lot. See Lot-Related Definitions.

Lot-Related Definitions.

- **Adjusted Lot.** A lot that has had one or more of its lot lines altered through a deed, or other instrument relocating a property line, that was recorded with the appropriate county recorder prior to July 26, 1979, or through an approved property line adjustment. An adjusted lot has a lot area that is equal to or larger than the original platted lot. See Figures 910-17 and 910-18.

Figure 910-18
Adjusted Lots with Equal Lot Areas as the Original Lots

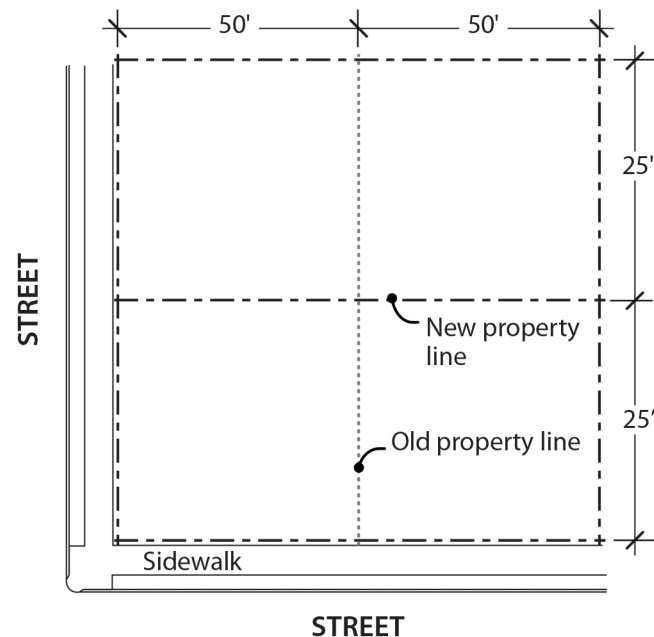

- **Corner Lot.** A lot, adjusted lot, lot remnant, or lot of record that has frontage on more than one intersecting street, and where the lot frontages intersect. A street that curves with angles that are 120 degrees or less, measured from the center line of the street, is considered two intersecting streets for the purpose of evaluating whether a lot is a corner lot. See Figure 910-4. A corner lot may also be a through lot.
- **Flag Lot.** A lot, adjusted lot, lot remnant, or lot of record with two distinct parts.
See Figure 910-5:
 - The flag, which is the only building site; and is located behind another lot; and
 - The pole, which connects the flag to the street; provides the only street frontage for the lot; and at any point is less than the minimum lot width for the zone.
- **Lot.** A lot is a legally defined piece of land other than a tract that is the result of a land division. This definition includes the State definition of both lot, (result of subdividing), and parcel, (result of partitioning). This definition also includes a lot that is smaller than the original platted lot solely because of condemnation or required dedication by a public agency for right-of-way. See also Ownership and Site.
- **Lot of Record.** A lot of record is a plot of land:
 - That was not created through an approved subdivision or partition;
 - That was created and recorded before July 26, 1979; and
 - For which the deed, or other instrument dividing the land, is recorded with the appropriate county recorder.
- **Lot Remnant.** A lot that has had one or more of its lot lines altered through a deed, or other instrument relocating a property line, that was recorded with the appropriate county recorder prior to July 26, 1979, or through an approved property line adjustment. A lot remnant has a lot area that less than the lot area of the original platted lot. This definition

does not include lots that are smaller than the original platted lot solely because of condemnation or required dedication by a public agency for right-of-way. See Figure 910-17.

- **Through Lot.** A lot, adjusted lot, lot remnant, or lot of record that has frontage on two streets, and where the lot frontages do not intersect. See Figure 910-4. A through lot may also be a corner lot.

Figure 910-17
Adjusted Lot and Lot Remnant

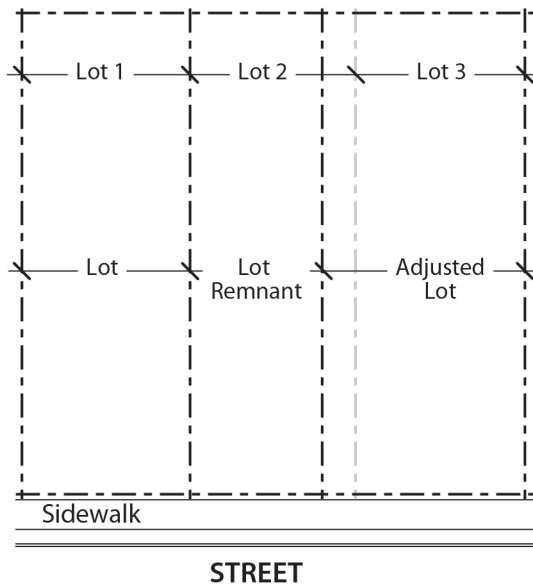

**Figure 910-5
Flag Lot**

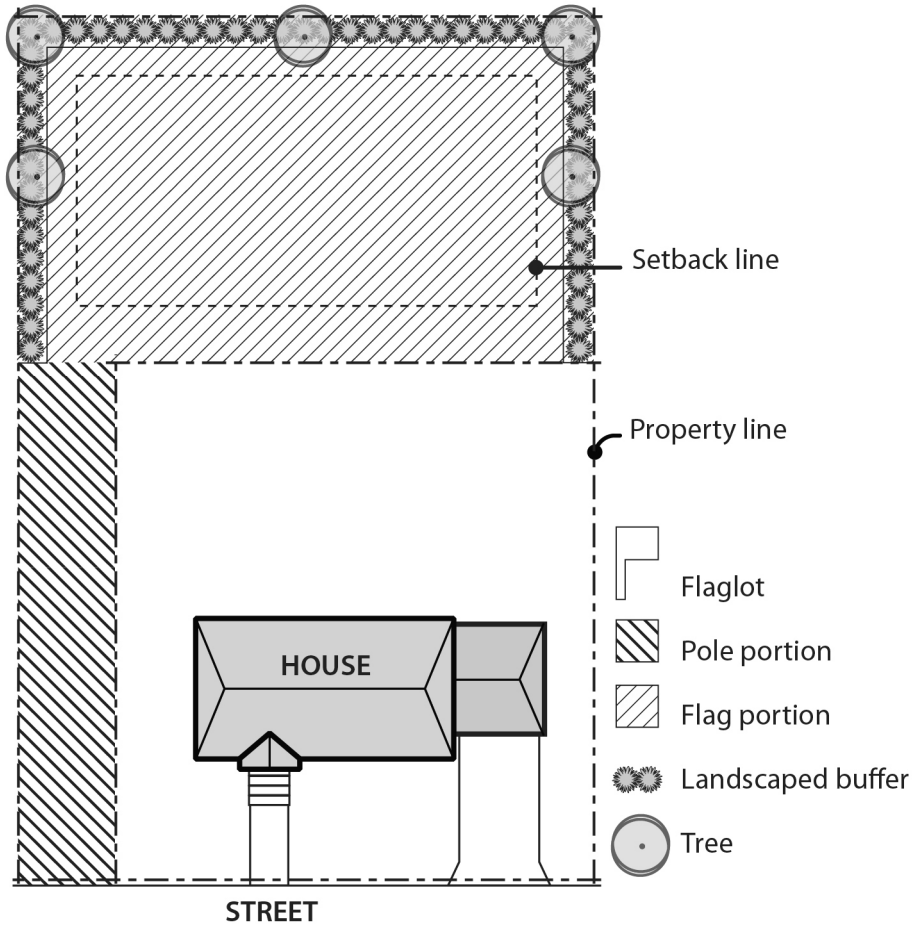

**Figure 910-4
Corner and Through Lots**

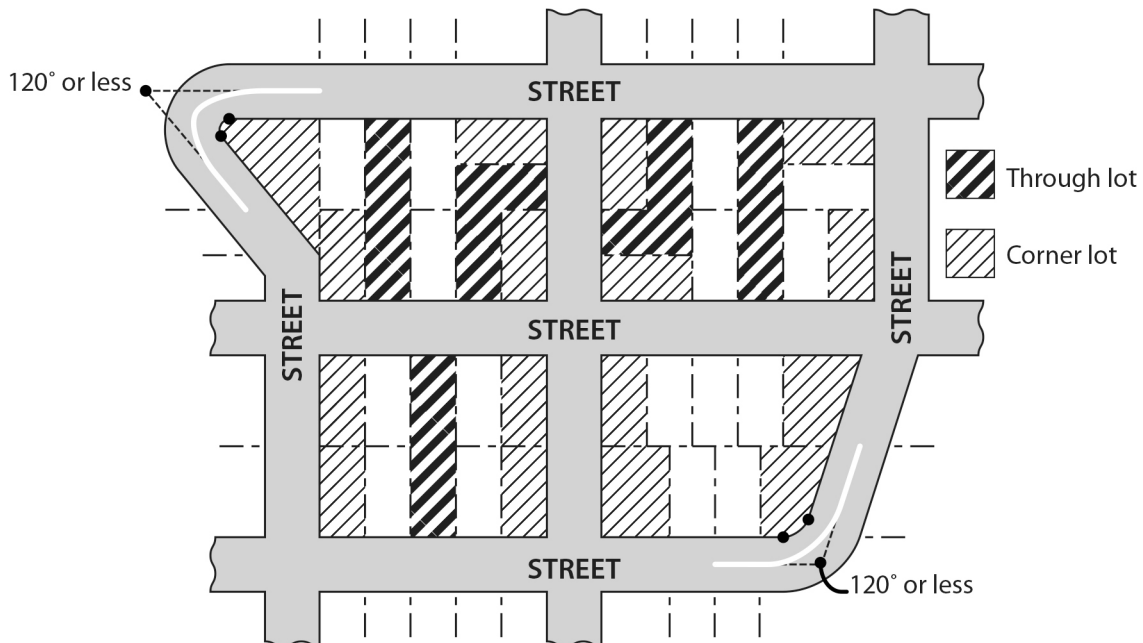

Lot Lines. The property lines along the edge of a lot, adjusted lot, lot of record, lot remnant, or site.

- **Front Lot Line.** A lot line, or segment of a lot line, that abuts a street. On a corner lot, the front lot line is the shortest of the lot lines that abut a street. If two or more street lot lines are of equal length, then the applicant or property owner can choose which lot line is to be the front. However, a through lot has two front lot lines regardless of whether the street lot lines are of equal or unequal length. See Figure 910-6.
- **Rear Lot Line.** A lot line that is opposite a front lot line. A triangular lot has two side lot lines but no rear lot line. For other irregularly shaped lots, the rear lot line is all lot lines that are most nearly opposite the front lot line. See Figure 910-8.
- **Side Lot Line.** A lot line that is neither a front or rear lot line. On a corner lot, the longer lot line which abuts a street is a side lot line. See Figure 910-6.
- **Side Street Lot Line.** A lot line that is both a side lot line and a street lot line. See Figures 910-6 and 910-7.
- **Street Lot Line.** A lot line, or segment of a lot line, that abuts a street. Street lot line does not include lot lines that abut an alley. On a corner lot, there are two (or more) street lot lines. Street lot line can include front lot lines and side lot lines. See Figures 910-6 and 910-7.

Lot of Record. See Lot-Related Definitions.

Lot Remnant. See Lot-Related Definitions.

**Figure 910-6
Front and Side Lot Lines**

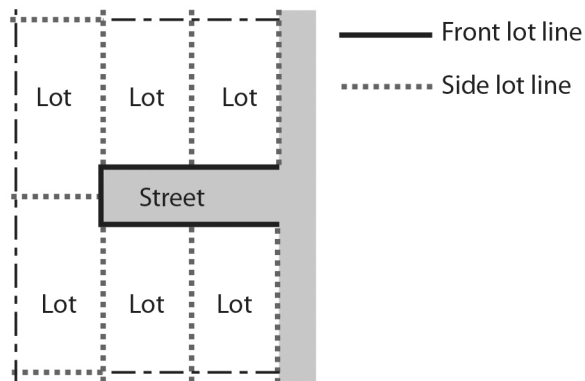

**Figure 910-7
Street Lot Lines**

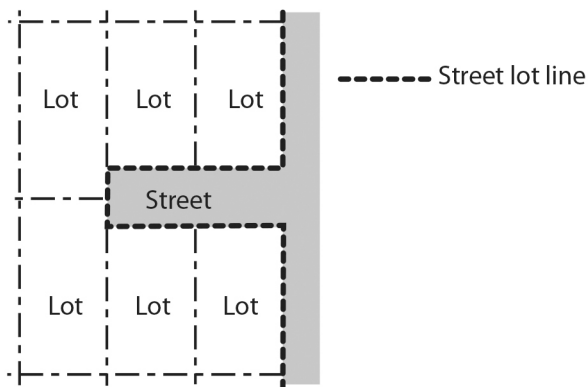

**Figure 910-8
Lot Lines on Irregular Lots**

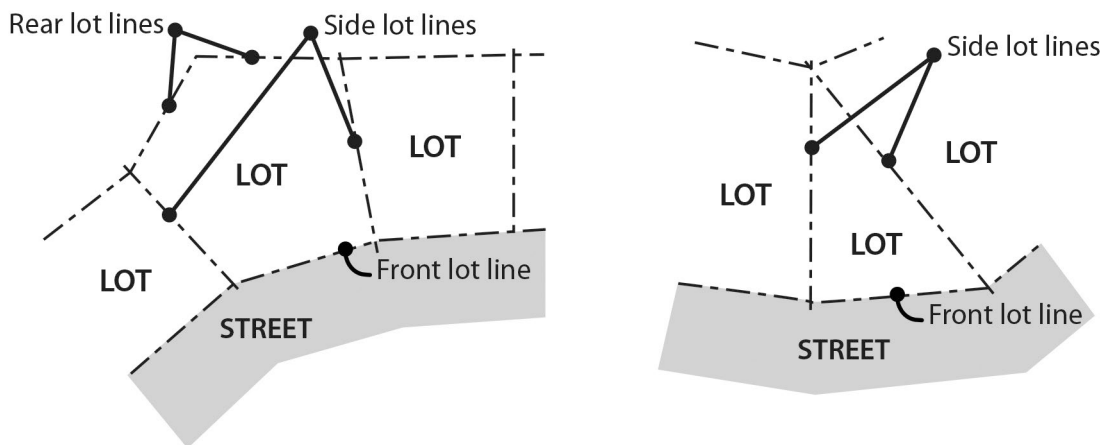

Main Entrance. A main entrance is the entrance to a building that most pedestrians are expected to use. Generally, each building has one main entrance. Main entrances are the widest entrance of those provided for use by pedestrians. In multi-tenant buildings, main entrances open directly into the building's lobby or principal interior ground level circulation space. When a multi-tenant building does not have a lobby or common interior circulation space, each tenant's outside entrance is a main entrance. In single-tenant buildings, main entrances open directly into lobby, reception, or sales areas.

Maintained street. A maintained street is a street that has been accepted for maintenance by the City of Portland, Multnomah County, or the State of Oregon. See Title 17.42, Property Owner Responsibility for Streets.

Maintenance. Actions, such as painting a previously painted surface or re-roofing using the same type of materials, performed to prevent a structure, or one of its constituent systems, from falling into a deteriorated condition.

Major Remodeling. Projects where the floor area is being increased by 50 percent or more, or where the cost of the remodeling is greater than the assessed value of the existing improvements on the site. Assessed value is the value shown on the applicable county assessment and taxation records for the current year.

Manufactured Dwelling. See Residential Structure Types.

Manufactured Dwelling Park. Four or more manufactured dwellings which are located on a single site for 30 days or more and intended for residential use. Manufactured dwelling park does not include sites where unoccupied manufactured dwellings are offered for sale or lease. See also Recreational Vehicle Park.

Manufactured Dwelling Space. The area occupied by a manufactured dwelling and its accessory uses and structures in a manufactured dwelling park.

Manufactured Home. See Residential Structure Types.

Marina. A facility which provides secure moorings for recreational or commercial boats. The term marina does not include houseboat moorages.

Market Garden. A site where food is grown to be sold. The food may be sold directly to consumers, restaurants, stores, or other buyers, or at Farmers Markets.

Mass Shelter. A building that contains one or more open sleeping areas, or is divided only by non-permanent partitions, and furnished with beds, cots, floor mats, or bunks. Individual bedrooms are not provided. The shelter may or may not have food preparation or shower facilities. The shelter is managed by a public or non-profit agency to provide shelter, with or without a fee, with no minimum length of stay. Where individual bedrooms are provided, the facility is a short term shelter. See also Outdoor Shelter and Short Term Shelter.

Mass Shelter Beds. Accommodation provided in a mass shelter. The number of beds is determined by the maximum number of people who can be given overnight accommodations at one time on the site.

Medium Truck. See Truck under Vehicle Types.

Mitigate. To rectify, repair, or compensate for impacts that result from other actions.

- **Off-site Mitigation.** Mitigation that does not take place on the site where the impact occurs.
- **On-site Mitigation.** Mitigation that takes place on the site where the impact occurs.

Mixed-Use. The combination on a site of residential uses with commercial or industrial uses.

Mobile Home. See Residential Structure Types.

Motor Home. See Recreational Vehicle, under Vehicle Types.

Motor Vehicle. See Vehicle Types.

Multi-Dwelling Development. See Residential Structure Types.

Multi-Dwelling Structure. See Residential Structure Types.

Near Shore Complexity. A combination of conditions within a river channel that includes at least one of the following: diverse in-water vegetation communities, variations in water flow depth and velocity, and a variety of structural elements such as rocks, logs, and rootwads.

Net Building Area. Gross building area, excluding parking areas.

New Development. See Development, New.

Noise Contour. A line that indicates the perimeter of areas that are within a specified Ldn/DNL level.

Nonconforming Development. An element of a development, such as a setback, height, or parking area, that was created in conformance with development regulations but which subsequently, due to a change in the zone or zoning regulations, is no longer in conformance with the current applicable development standards.

Nonconforming Residential Density. A residential use that is an allowed use in the zone and that was constructed at a lawful density, but which subsequently, due to a change in the zone or zoning regulations, now has greater density than is allowed in the zone.

Nonconforming Situation. A Nonconforming Residential Density, Nonconforming Development, or Nonconforming Use. A situation may be nonconforming in more than one aspect. For example, a site may contain a nonconforming use and also have some nonconforming development. See also Nonconforming Residential Density, Nonconforming Development, and Nonconforming Use.

Nonconforming Use. A use that was allowed by right when established or a use that obtained a required land use approval when established, but that subsequently, due to a change in the zone or zoning regulations, the use or the amount of area devoted to the use is now prohibited in the zone.

Nondiscretionary Reviews. A nondiscretionary review is one where compliance with the regulations can be determined based on objective standards. Decisions are made ministerially; they do not require a public hearing or notice. Examples of these reviews include: whether the proposed use is or is not allowed, whether the site area is or is not large enough for the proposed number of housing units, and whether the proposed building meets all setback, height, and parking requirements.

Nuisance Plants List. The Nuisance Plants List is part of the *Portland Plant List*, published by the Bureau of Planning and Sustainability.

Operator. A person undertaking a development, the proprietor of a use or development, or the owner of the land underlying a development. The operator may also be the manager or other person who has oversight responsibility for the day to day operations of the use or development.

Ordinary Low Water. The line on the bank or shore to which the low water ordinarily recedes annually in season. On the Willamette River, ordinary low water is defined as 8' North American Vertical Datum of 1988 (NAVD88) or 5.90' City of Portland datum.

Organized Sports. Any athletic team play (scheduled games), by any ages, on a physically defined sports field (natural or synthetic). Includes both scheduled athletic games associated with school programs and non-school programs. Examples include T-ball, high-school football, youth baseball, and soccer clubs. Organized sports does not include practice or other unstructured play such as pick-up games or impromptu use and does not include play on hard-surfaced courts.

Outdoor Shelter. Individual shelters grouped together in an outdoor setting. Examples of individual shelters include tents, yurts, huts, cabins, vehicles or other similar accommodation that do not contain sanitary or cooking facilities, and recreational vehicles with or without cooking and sanitary facilities. The shelter is managed by a public agency or a non-profit agency, with or without a fee, and with no minimum length of stay. An outdoor shelter may or may not include buildings that have food preparation or sanitary facilities. See also Mass Shelter and Short Term Shelter.

Outfall. A location where collected and concentrated water is discharged. The water may be treated or untreated. Outfalls include discharge from stormwater management facilities, drainage pipe systems, constructed open channels, and vegetated swales.

Owner. The owner of the title to real property or the contract purchaser of real property of record, as shown on the latest assessment records in the Office of the County Assessor. Owner also includes a deed holder or contract purchaser whose name does not appear in the latest assessment records, but who presents to the City a copy of a deed or contract of sale showing date, book, and page of recording.

Ownership. An ownership is one or more contiguous lots that are owned by the same person, partnership, association, or corporation. Ownership also includes lots that are in common ownership but are separated by a shared right-of-way. See Figure 910-9. See also, Lot and Site.

**Figure 910-9
Ownership**

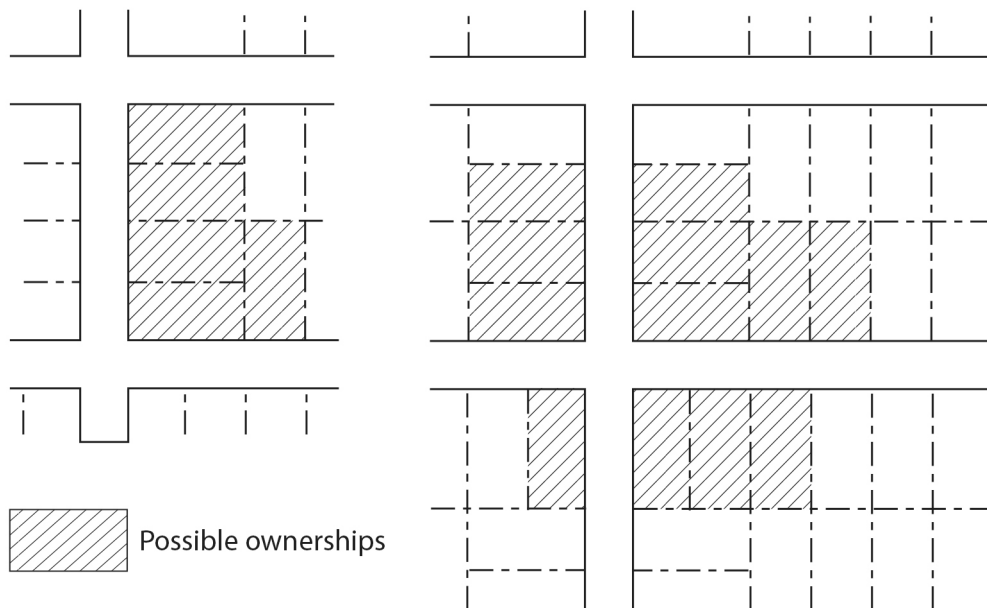

Parcel. See Lot.

Parking Area. A parking area is all the area devoted to the standing, maneuvering, and circulation of motor vehicles. Parking areas do not include driveways or areas devoted exclusively to non-passenger loading. See also, Driveway, Garage, Structured Parking, and Vehicle Areas.

Parking Space. A space designed to provide standing area for a motor vehicle.

Partial Street. See Street Types.

Passenger Vehicle. See Vehicle Types.

Paved Area. An uncovered, hard-surfaced area or an area covered with a perforated hard surface (such as "Grasscrete") that is able to withstand vehicular traffic or other heavy-impact uses. Graveled areas are not paved areas.

Peace Officer. Peace Officer includes a member of the Oregon State Police, sheriff, constable, marshal, or officer of the Bureau of Police.

Peak Hour Service. Service provided by public transit to a site, measured on weekdays between 7:00 AM and 8:30 AM and between 4:00 PM and 6:00 PM. The service is measured in one direction of travel, and counts bus lines, streetcars, and light rail lines.

Pedestrian Access Route. A route between the main entrance of a building and short-term bicycle parking that is hard surfaced, free of obstacles, and at width equal to that of the Pedestrian standards of the Base Zone. The route can be on sidewalks, walkways, plazas, and other hard-surfaced areas.

Pedestrian Connection. A pedestrian connection generally provides a through connection for bicyclists and pedestrians between two streets or two lots. It may be a sidewalk that is part of a

street that also provides vehicle access, or it may be a self-contained street created solely for pedestrians and bicyclists.

Pedestrian-Oriented Development. See Development Types.

Permanent Disturbance Area. See Disturbance Area, Permanent.

Person. Any person, partnership, association, or corporation.

Personal Wireless Service Facility. A type of Radio Frequency Transmission Facility that provides telecommunication service as defined by the Federal Telecommunications Act of 1996. These facilities include technologies that currently exist or that may be developed in the future, including but not limited to cellular, personal communications services, specialized mobile radio, enhanced specialized mobile radio, paging, and similar Federal Communications Commission (FCC)-licensed commercial wireless telecommunications services.

Phased Development Plan. A phased development plan includes the following:

- A site plan showing the proposed final development of the site and phases, including the initial and interim phases.
- A written statement describing each phase, including the potential uses, and the approximate timeline for each phase of development.

Planning and Sustainability Director. The Director of the City of Portland Bureau of Planning and Sustainability, or the Director's designee.

Plat. Diagrams, drawings and other writing containing all the descriptions, locations, dedications, provisions, and information concerning a land division. This term includes the State law definitions of "partition plat" and "subdivision plat".

Plaza. An area generally open to the public on a controlled basis and used for passive recreational activities and relaxation. Plazas are paved areas typically provided with amenities, such as seating, drinking and ornamental fountains, art, trees, and landscaping, for use by pedestrians.

Plot. A piece of land created by a partition, subdivision, deed, or other instrument recorded with the appropriate county recorder. This includes a lot, an adjusted lot, a lot remnant, a lot of record, a tract, or a piece of land created through other methods.

Pollution Reduction Facility. A facility specifically designed to remove pollutants from stormwater. Pollutants may include sediment, heavy metals, or plant nutrients. These facilities generally include native wetland plants which blend into surrounding habitat.

Potential Landslide Hazard Area. Potential Landslide Hazard Areas are shown on the City's Potential Landslide Hazard Areas Map.

Practicable. Capable of being done after taking into consideration cost, existing technology, and logistics in light of overall project purposes.

Primary Structure. A structure or combination of structures of chief importance or function on a site. In general, the primary use of the site is carried out in a primary structure. The difference between a primary and accessory structure is determined by comparing the size, placement, similarity of design, use of common building materials, and the orientation of the structures on a site.

Primary Use. An activity or combination of activities of chief importance on the site. One of the main purposes for which the land or structures are intended, designed, or ordinarily used. A site may have more than one primary use.

Private Helicopter Landing Facility. See Helicopter Landing Facility (HLF).

Project. An existing or proposed development.

Property Line Adjustment. The relocation of a single common property line between two abutting properties. Also see Exchange Parcel. See Figure 910-10.

**Figure 910-10
Property Line Adjustment**

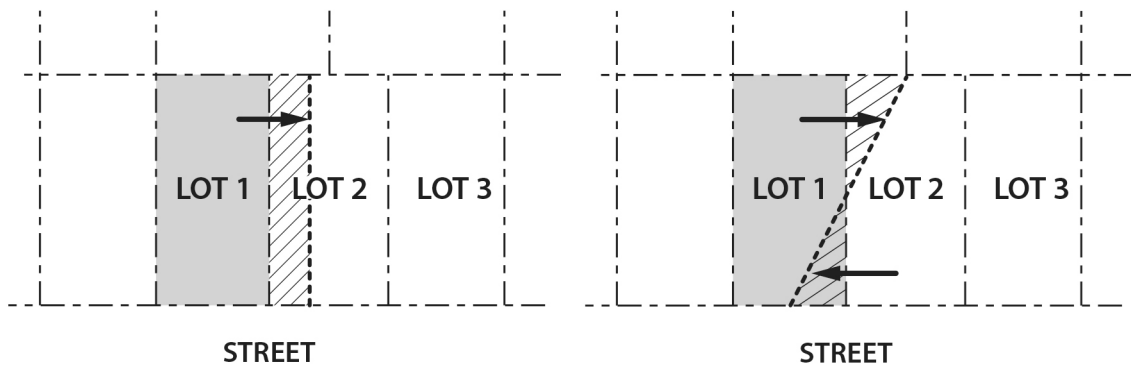

Lot 1 may assume a portion of Lot 2 through a Property Line Adjustment Review.

Lot 1 may assume a portion of Lot 2 and Lot 2 may assume a portion of Lot 1 through one Property Line Adjustment Review.

 Exchange parcel

Pruning. The cutting away or limbing of tree or shrub branches. Pruning does not include the removal of any portion of the top of the tree, sometimes referred to as "topping". Topping a tree is considered destruction of the tree.

Public Access Easement. A public access easement is an easement granted to the public for all the purposes for which a public sidewalk may be used, including but not limited to, pedestrian and bicycle travel.

Public Safety Facility. A facility necessary to respond to an immediate hazard to the public health and safety, and that is owned, leased, or operated by the City of Portland. Public safety facilities include fire and police stations, flood control facilities, water towers and pump stations needed for emergency service, and emergency communication broadcast facilities.

Radio or Television Broadcast Facility. A type of Radio Frequency Transmission Facility that disseminates radio and television communications intended to be received by the public, including the direct transmission or by the intermediary of relay stations.

Rail Right-Of-Way. See Right-Of-Way, Rail.

Rear Lot Line. See Lot Lines.

Rear Setback. See Setback.

Recognized Organization. An organization formally recognized by the Office of Community & Civic Life pursuant to City Code 3.96.060, and organizations participating in Civic Life's Diversity and Civic Leadership Program.

Recreational Vehicle. See Vehicle Types.

Recreational Vehicle Park. A commercial use providing space and facilities for motor homes or other recreational vehicles for recreational use or transient lodging. There is no minimum required stay in a recreational vehicle park. Uses where unoccupied recreational vehicles are offered for sale or lease, or are stored, are not included as Recreational Vehicle Parks. See also Manufactured Dwelling Park.

Recycling Drop-Off Center. A facility for the drop-off and temporary holding of materials such as paper, cardboard, glass, metal, plastic, batteries, and motor oil. Processing of materials is limited to glass breaking and separation. Recycling materials are not sold to a recycling drop-off center. A recycling drop-off center is intended for household or consumer use. Use by commercial or industrial establishments is not included. Unattended drop-off stations for single materials, such as newsprint, are also not included.

Recycling Operation. A use where one or more recycling materials are accumulated, stored, sorted, or processed. A recycling operation may get recycling materials from drop-off centers, from a household or business pick-up operation, or from commercial or industrial uses. Materials may be processed on site or accumulated in large quantities for eventual sale or transfer to other processors. Recycling operation does not include the processing of yard debris or other decomposable material except for clean paper products.

Regional Attractor. A Major Event Entertainment Use, Commercial Outdoor Recreation Use, or Community Service Use with more than 100,000 square feet of net building area.

Remediation. The restoration and enhancement of resources and/or functional values lost as the result of a violation of the environmental zone regulations.

Renewable Fuel. Renewable fuels (such as biodiesel, biomethane, and clean hydrogen) are produced from non-petroleum, non-natural gas renewable resources and have less than 5 percent fossil fuel content.

Repair. Actions to fix or mend a damaged or deteriorated structure, or one of its constituent systems, with similar material while retaining sound parts or elements.

Replacement. Actions to substitute one material or system for another.

Residential Facility. A residence for 6 to 15 physically or mentally disabled persons, and for staff persons. The facility may provide residential care alone, or in conjunction with training or treatment. This definition includes the State definition of Residential Facility.

Residential Home. A residence for five or fewer physically or mentally disabled persons, and for staff persons. The residence may provide residential care alone, or in conjunction with training or treatment. This definition includes the State definition of Residential Home.

Residential Structure Types

- **Accessory Dwelling Unit.** An additional dwelling unit created on a lot with a primary dwelling unit. The additional unit is smaller than the primary dwelling unit except when the accessory dwelling unit is in an existing basement. The accessory dwelling unit includes its own independent living facilities including provision for sleeping, cooking, and sanitation,

and is designed for residential occupancy by one or more people, independent of the primary dwelling unit. Kitchen facilities for cooking in the unit are described in Section 29.30.160 of Title 29, Property and Maintenance Regulations. The unit may have a separate exterior entrance or an entrance to an internal common area accessible to the outside.

- **Attached Duplex.** A duplex, **located on its own lot**, that shares one or more common or abutting walls with one or more dwelling units. The common or abutting wall must be shared for at least 25 percent of the length of the side of the dwelling.
- **Attached House.** Except for individual dwelling units on lots created through a middle housing land division, a dwelling unit, **located on its own lot**, that shares one or more common or abutting walls with one or more dwelling units. The common or abutting wall must be shared for at least 25 percent of the length of the side of the building. The shared or abutting walls may be any wall of the buildings, including the walls of attached garages. An attached house does not share common floor/ceilings with other dwelling units. An attached house is also called a rowhouse or a common-wall house. See Figure 910-16.

Figure 910-16
Attached Houses

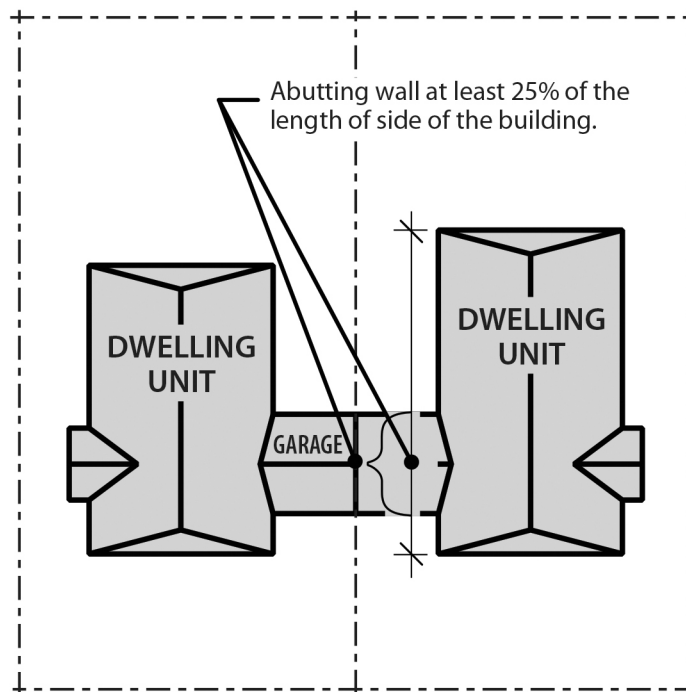

- **Congregate Housing Facility.** A building, buildings, or portion of a building that includes separate bedrooms and individual or shared bathrooms but does not include a kitchen or if it does include a kitchen the number of kitchens is less than one kitchen per 12 bedrooms.
- **Cottage Cluster.** A grouping of no fewer than three and no more than 16 individual detached primary dwelling units on one lot. A cottage cluster on a site that is divided through a middle housing land division remains a cottage cluster.
- **Duplex.** A building that contains two primary dwelling units on one lot. In this case, the units must share a common wall or common floor/ceiling. In the single-dwelling zones, a duplex

can also be two detached primary dwelling units on one lot. A duplex on a site that is divided through a middle housing land division remains a duplex.

- **Dwelling Unit.** A building, or a portion of a building, that has independent living facilities including provisions for sleeping, cooking, and sanitation, and that is designed for residential occupancy by a group of people, except that a congregate housing facility is not a dwelling unit. Kitchen facilities for cooking are described in Section 29.30.160 of Title 29, Property and Maintenance Regulations. Buildings with more than one set of cooking facilities are considered to contain multiple dwelling units unless the additional cooking facilities are clearly accessory, such as an outdoor grill.
- **Fourplex.** A structure that contains four primary dwelling units on one lot. Each unit must share a common wall or common floor/ceiling with at least one other unit. A fourplex on a site that is divided through a middle housing land division remains a fourplex.
- **House.** Except for a detached dwelling unit on a lot that was created through a middle housing land division, a detached dwelling unit located on its own lot.
- **Houseboat Moorage.** A facility which provides moorings for houseboats.
- **Manufactured Dwelling.** A dwelling unit constructed off of the site which can be moved on the public roadways. Manufactured dwellings include residential trailers, mobile homes, and manufactured homes.
 - **Manufactured Home.** A manufactured home is a manufactured dwelling constructed after June 15, 1976 in accordance with federal manufactured housing construction and safety standards (HUD code) in effect at the time of construction.
 - **Mobile Home.** A mobile home is a manufactured dwelling constructed between January 1, 1962, and June 15, 1976, in accordance with the construction requirements of Oregon mobile home law in effect at the time of construction.
 - **Residential Trailer.** A residential trailer is a manufactured dwelling constructed before January 1, 1962, which was not constructed in accordance with federal manufactured housing construction and safety standards (HUD code), or the construction requirements of Oregon mobile home law.
- **Multi-Dwelling Development.** Except for cottage clusters, a grouping of individual structures where each structure contains 1 or more dwelling units. The land underneath the structures is not divided into separate lots. The key characteristic of this housing type is that there is no requirement for the structures on the sites to be attached.
- **Multi-Dwelling Structure.** A structure that contains five or more dwelling units that share common walls or floor/ceilings with one or more units. The land underneath the structure is not divided into separate lots. Multi-dwelling includes structures commonly called garden apartments, apartments, and condominiums.
- **Triplex.** A structure that contains three primary dwelling units on one lot. Each unit must share a common wall or common floor/ceiling with at least one other unit. A triplex on a site that is divided through a middle housing land division remains a triplex.

Residential Trailer. See Residential Structure Types.

Resource Enhancement. The modification of resources or functional values. This may include the short-term loss of resources or functional values, to achieve improved quality or quantity of the resource or functional values in the long term or for future desired conditions. It can include actions that result in increased animal and plant species, increased numbers of types of natural habitat, and/or increased amount of area devoted to natural habitat. It may also include improvements in

scenic views and sites, increased capacity for stormwater detention or infiltration, increased or improved floodplain function, changes in water quantity or quality, changes in ecosystem type, or other improvements to resources or functional values. A resource enhancement project must result in a net gain in total functional value and improvement in the quality or quantity of resources on the site.

Retaining Wall. A vertical, or near vertical structure, that holds back soil or rock, and prevents movement of material down slope or erosion on a site.

Review Body. The person or group who is assigned to make decisions on land use reviews, whether initially or on appeal. Review body includes the Director of BDS, the Adjustment Committee, the Hearings Officer, the Historic Landmarks Commission, Design Commission, Planning Commission, and the City Council.

Right-Of-Way. An area that allows for the passage of people or goods. Right-of-way includes passageways such as freeways, pedestrian connections, alleys, and all streets. A right-of-way may be dedicated or deeded to the public for public use and under the control of a public agency, or it may be privately owned. A right-of-way that is not dedicated or deeded to the public will be in a tract. Where allowed by Section 33.654.150, Ownership, Maintenance, and Public Use of Rights-Of-Way, the right-of-way may be in an easement.

Right-of-way, Rail. A public or private right-of-way, for the purpose of allowing rail travel.

Riparian Areas. Lands which are adjacent to rivers, streams, lakes, ponds, and other water bodies. They are transitional between aquatic and upland zones, and as such, contain elements of both aquatic and terrestrial ecosystems. They have high water tables because of their close proximity to aquatic systems, soils which are usually made up largely of water-carried sediments, and some vegetation that requires free (unbound) water or conditions that are more moist than normal.

Riparian Functional Values. The functional values provided along a healthy river shore, including: food and habitat for fish and wildlife; dynamic channel forming processes; cool clean water; an amount and timing of water flow that reflects the natural hydrologic regime; and a microclimate beneficial to fish and wildlife.

River Bank Complexity. A combination of conditions along a river shore that includes at least one of the following: diverse vegetation communities, variations in bank slope and shoreline roughness, and a variety of structural elements such as rocks, log, and rootwads.

River-Dependent. A use which can be carried out only on, in, or adjacent to a river because it requires access to the river for waterborne transportation or recreation. River-dependent also includes development, which by its nature, can be built only on, in, or over a river. Bridges supported by piers or pillars, as opposed to fill, are river-dependent development.

River-Related. A use or development which is not directly dependent upon access to a water body but which provides goods or services that are directly associated with river-dependent land or waterway use or development, and which, if not located adjacent to water, would result in a public loss of quality in the goods or services offered. Residences (including houseboats), parking areas, spoil and dump sites, roads and highways, restaurants, businesses, factories, and recreational vehicle parks are not generally considered dependent or related to water. Recreational trails and viewpoints adjacent to the river are river-related development. Bridge exit and entrance ramps supported by piers or pillars, as opposed to fill, are river-related development. Removal or remedial

actions of hazardous substances conducted under ORS 465.200 through 465.510 and 475.900 are considered river-related development for the duration of the removal or remedial action.

Roadway. The portion of a right-of-way that is improved for motor vehicle travel. Roadway includes vehicle travel lanes and on-street parking areas. Roadway does not include area devoted to curbs, parking strips, or sidewalks.

Scenic Corridor. A scenic corridor is a linear scenic resource. It may include streets, bikeways, trails, or waterways (rivers, creeks, sloughs) through parks, natural areas, or urban areas. The corridor may include scenic views along it, but may also be valued for its intrinsic scenic qualities, such as a winding road through a wooded area. See also, View Corridor.

Scenic Site. A scenic site is an area valued for its aesthetic qualities. The area may be made up primarily of natural vegetated cover and water, or include structures and manmade landscaping. Scenic sites may include scenic viewpoints, but do not necessarily do so.

Scenic View. A scenic view is a view that may be framed, wide angle, or panoramic and may include natural and/or manmade structures and activities. A scenic view may be from a stationary viewpoint or be seen as one travels along a roadway, waterway, or path. A view may be to a far away object, such as a mountain, or of a nearby object, such as a city bridge.

Scenic Viewpoint. A scenic viewpoint is a location from which to enjoy a scenic view. A viewpoint may be a generalized location, such as a butte, and include several vantage points where the view may be seen to best advantage, or a single observation point.

School Site. An improved site that has, formerly had, or proposes to have a school use on it and that is owned by the entity that runs, ran, or will run the school.

Seep or Spring. An area where groundwater is discharged onto the land surface, creating either saturated soil conditions or visible flow at the land surface.

Services. For the purposes of the 600s series of chapters, services are water service, sanitary sewage disposal, stormwater management systems, and rights-of-way.

Setback. The minimum distance required between a specified object, such as a building and another point. Setbacks are usually measured from lot lines to a specified object. Unless otherwise indicated, an unspecified setback refers to a building setback. In addition, the following setbacks indicate where each setback is measured from. See Chapter 33.930, Measurements, for measurement information.

- **Front Setback.** A setback that is measured from a front lot line.
- **Garage Entrance Setback.** A setback that is measured from a street lot line to the entrance to a garage or carport. It is essentially a minimum driveway length. See Chapter 33.930, Measurements, for more specific measurement information.
- **Rear Setback.** A setback that is measured from a rear lot line.
- **Side Setback.** A setback that is measured from a side lot line.
- **Street Setback.** A setback that is measured from a street lot line.

Shallow Water Habitat. Land and riverbed located between the ordinary high water mark and 20 feet below the ordinary low water mark of the Willamette or Columbia Rivers.

Shelter Beds. See Mass Shelter Beds.

Short-Term Bicycle Parking. Short-term bicycle parking serves shoppers, customers, messengers, and other visitors to a site who generally stay for a short time. See also Long-Term Bicycle Parking.

Short Term Shelter. A building that contains one or more individual bedrooms, and where occupancy of all rooms may be arranged with no minimum length of stay. The short term shelter facility may or may not have food preparation facilities, and shower or bath facilities may or may not be shared. The facility is managed by a public or non-profit agency to provide shelters, with or without a fee. Examples include transitional housing, and emergency shelters where individual rooms are provided. Where individual bedrooms are not provided, the facility is a mass shelter. See also Mass Shelter and Outdoor Shelter.

Short Term Parking. Parking having a duration of four hours or less.

Side Lot Line. See Lot Lines.

Side Setback. See Setback.

Side Street Lot Line. See Lot Lines.

Sign. As defined in Title 32, Signs and Related Regulations

Significant Detrimental Impact. An impact that affects the natural environment to the point where existing ecological systems are disrupted or destroyed. It is an impact that results in the loss of vegetation, land, water, food, cover, or nesting sites. These elements are considered vital or important for the continued use of the area by wildlife, fish, and plants, or the enjoyment of the area's scenic qualities.

Site. For land divisions, the site is the lots, lots of record, or tracts proposed to be divided or reconfigured. For development on a lot that was created through a middle housing land division, the site is the original site prior to being divided. For all other purposes, the site is an ownership except as follows:

- If a proposed development includes more than one ownership, then all the ownerships are included as the site.
- If a proposed development includes only a portion of an ownership, and the balance of the ownership is vacant, then the applicant may choose to define the site as the portion of the ownership that is proposed for development.
- If a proposed development includes only a portion of an ownership, and there is other development on the ownership, then the applicant may choose to define the site as the portion of the ownership that is currently developed plus the portion proposed for development.

Site Frontage. The part of a site that abuts a street. See also, Block Frontage.

Small Scale Energy Production. Energy production where the energy is derived from the following:

- Solar;
- Small wind energy turbines;
- Geothermal;
- Hydroelectric systems that produce up to 100 kW;
- Waste heat capture, heat exchange or co-generation of energy as a byproduct of another manufacturing process;

- The following systems that use only biological material or byproducts produced, harvested or collected on-site. Up to 10 tons a week of biological material or byproducts from other sites may be used where the base zone regulations specifically allow it:
 - **Biogas.** Generation of energy by breaking down biological material in anaerobic conditions to produce gas that can be used to generate electricity or heat. The process generally occurs inside a closed system such as a tank or container.
 - **Biomass.** Generation of energy through the combustion of biological material to produce heat, steam, or electricity.
- Any of the methods listed here or natural gas used to produce steam, heat or cooling, with an output up to 1 megawatt.

See also Utility Scale Energy Production, and Wind Energy Turbine.

Special Flood Hazard Area. Land area covered by the floodwaters of the base flood, as shown on the Federal Emergency Management Agency (FEMA) maps in effect on November 26, 2010. The base flood is the flood having a one percent chance of being equaled or exceeded in any given year. This is the regulatory standard also referred to as the “100-year flood.”

Stormwater Facility. A facility designed to improve the quality and manage the quantity of stormwater runoff. Stormwater facilities include vegetated and sand filters, wet or dry ponds, marshes, infiltration facilities, and structural storm sewer devices. Stormwater facilities do not include conveyance systems that are meant only for conveying the stormwater from one place to another and do not affect the quality or quantity of the stormwater.

Stormwater Management System. A stormwater facility, and a conveyance system or an outfall.

Stream. An area where enough natural surface water flows to produce a stream channel, such as a river or creek, that carries flowing surface water during some portion of the year. This includes:

- The water itself, including any vegetation, aquatic life, or habitat;
- Beds and banks below the high water level which may contain water, whether or not water is actually present;
- The floodplain between the high water level of connected side channels;
- Beaver ponds, oxbows, and side channels if they are connected by surface flow to the stream during a portion of the year; and
- Stream-associated wetlands.

See also Identified Streams.

Stream Channel. An area which demonstrates evidence of the passage of water. The depression between the banks worn by the regular and usual flow of the water. The channel need not contain water year-round. This definition does not include irrigation ditches, canals, storm or surface water runoff devices, or other entirely artificial watercourses.

Street. See Street Types.

Street Lot Line. See Lot Lines.

Street Setback. See Setback.

Street-facing Facade. All the wall planes of a structure as seen from one side or view that are at an angle of 45 degrees or less from a street lot line. See Figure 910-12.

Figure 910-12
Street-facing Facade

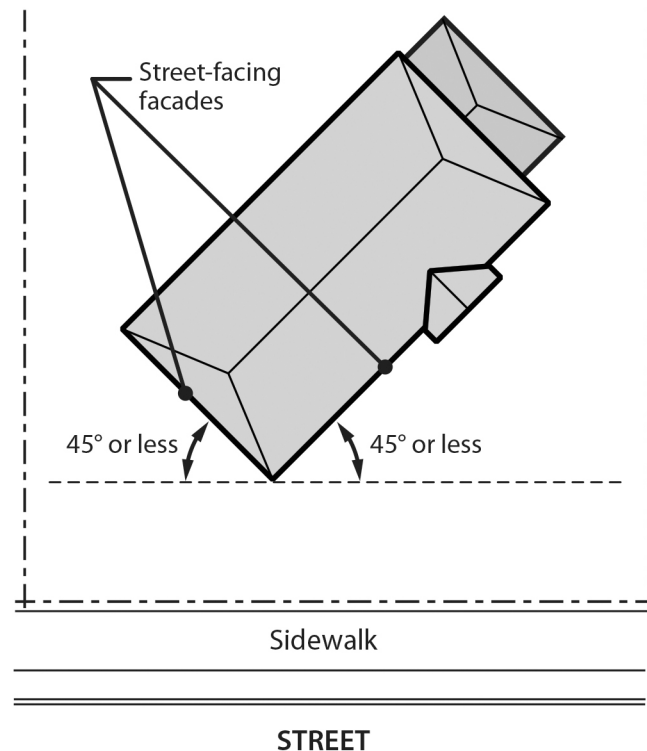

Streetcar Alignment. A street, right-of-way, or easement that has a streetcar line in it. For comparison, see Light Rail Alignment.

Streetcar Line. A public rail transit line that generally operates at grade level and that provides local transit service with stops that are close together. A streetcar line is designed to share a street with traffic, although it may also use a separate right-of-way or easement. For comparison, see also Light Rail Line.

Street Types. See also Alley, Pedestrian Connection, Right-of-Way, and Roadway.

- **Arterial.** Any street that is not a Local Service Traffic Street according to the Transportation System Plan. It includes Regional Trafficways, Major City Traffic Streets, District and Neighborhood Collectors, and Traffic Access Streets.
- **Common Green.** A street that provides for pedestrian and bicycle access, but not vehicle access, to abutting property and generally provides a common area for use by residents. A common green may function as a community yard. Hard and soft landscape features may be included in a common green, such as groundcover, trees, shrubs, surfaced paths, patios, benches, or gazebos.
- **Dead-End Street.** A street that connects to another street at only one end, or extends from an existing dead-end street. Dead-end streets serve 2 or more lots that have frontage only on the dead-end street. A pedestrian connection may extend from the end of a dead-end street to connect with another street of any type, or with another pedestrian connection.
- **Local Service Street.** A street that is a Local Service Traffic Street according to the Transportation System Plan.

- **Partial Street.** A partial street is one or more parts of a dead-end street or through street; each part usually is located on a different site. Partial streets are created when a street will be completed in stages, on more than one site. Partial streets may include the whole or part of a turnaround, part of the total width, or part of the total length.
- **Shared Court.** A street that is designed to accommodate – within the same circulation space – access for vehicles, pedestrians, and bicycles to abutting property. Instead of a sidewalk area that is separate from vehicle areas, a shared court is surfaced with paving blocks, bricks or other ornamental pavers to clearly indicate that the entire street is intended for pedestrians as well as vehicles. A shared court may also include traffic calming measures to ensure safe co-existence of pedestrians, vehicles, and bicycles. Like a common green, a shared court may function as a community yard. Hard and soft landscape features and street furniture may be included in a shared court, such as trees, shrubs, lighting fixtures, and benches.
- **Street.** A right-of-way that is intended for motor vehicle, pedestrian or bicycle travel or for motor vehicle, bicycle or pedestrian access to abutting property. For the purposes of this Title, street does not include alleys, rail rights-of-way that do not also allow for motor vehicle access, or the interstate freeways and the Sunset Highway including their ramps.
- **Through Street.** A street that connects to other streets at both ends.
- **Transit Street.** A street that is classified in the Transportation System Plan as:
 - A Major Transit Priority Street, Transit Access Street, or Community Transit Street; or
 - A Regional Transitway not also classified as a Regional Trafficway, according to the Transportation System Plan. Regional Transitways that are entirely subsurface are not included for the purposes of this Title.

Structure. Any object constructed in or on the ground. Structure includes buildings, decks, fences, towers, flag poles, signs, and other similar objects. Structure does not include paved areas or vegetative landscaping materials.

Structured Parking. A covered structure or portion of a covered structure that provides parking areas for motor vehicles. Parking on top of a structure—where there is gross building area below the parking, but nothing above it—is structured parking. The structure can be the primary structure for a Commercial Parking facility or be accessory to multi-dwelling residential, commercial, employment, industrial, institutional, or other structures. A structure that is accessory to a house, attached house, duplex, triplex, fourplex, cottage cluster, manufactured dwelling, or houseboat is a garage and is not included as structured parking. See also Garage, Parking Area, and Underground Parking.

Superblock. A continuous area, either in single or multiple ownerships, which includes a vacated street and which has a total gross area in private property of at least 75,000 square feet.

Supermarket. A supermarket is a retail store with more than 20,000 square feet of net building area, selling a complete assortment of food, food preparation and wrapping materials, and household cleaning and servicing items.

Surface Parking. A parking area for motor vehicles where there is no gross building area below the parking area and no gross building area or roof above it. Area occupied by small, permanent buildings, such as booths used by parking attendants, is not parking area. Temporary vending carts are not gross building area.

Temporary Disturbance Area. See Disturbance Area, Temporary.

Through Lot. See Lot-Related Definitions.

Through Street. See Street Types.

Top of Bank. The largest decrease in slope that is 10 percent or greater between the ordinary high water mark of a water body and a point 50 feet landward from the ordinary high water mark. See Section 33.930.150, Measuring Top of Bank. If there is no decrease in slope that is 10 percent or greater within a distance of 50 feet from the ordinary high water mark, then the top of bank will be the default location described in Section 33.930.150, Measuring Top of Bank.

Topping. The inappropriate pruning practice used to reduce tree height by cutting to a predetermined crown limit without regard to tree health or structural integrity. Topping does not include acceptable pruning practices as described in the American National Standards Institute (ANSI) "A 300 Pruning Standards" and companion "Best Management Practices for Tree Pruning" published by the International Society of Arboriculture, such as crown reduction, utility pruning, or crown cleaning to remove a safety hazard, dead or diseased material.

Tower. A tall structure with the intended purpose of elevating a Radio Frequency Transmission Facility high above the ground. This definition includes but is not limited to a tower, pole, or mast over 20 feet tall.

Tract. A piece of land created and designated as part of a land division that is not a lot, adjusted lot, lot remnant, lot of record, or a public right-of-way. Tracts are created and designed for a specific purpose. Land uses within a tract are restricted to those uses consistent with the stated purpose as described on the plat, or in the maintenance agreements, or through Conditions, Covenants and Restrictions (CC&Rs). Examples include stormwater management tracts, private street or alley tracts, tree preservation tracts, environmental resource tracts, and open space tracts.

Transit Station. A location where light rail vehicles stop to load or unload passengers. For purposes of measuring, the Transit Station consists of the station platform.

Transit Street. See Street Types.

Transportation Management Association. An organization devoted to managing transportation or parking within a local community. A main goal for a Transit Management Association is to reduce reliance on the automobile for both work and non-work trips. A Transit Management Association typically provides information, programs, and activities that encourage the use of carpooling, transit, and other alternative modes of travel along with efficient use of parking resources.

Tree Grove. A group of six or more native trees at least 12 inches in diameter, or Oregon white oak trees or Pacific madrone trees that are at least 6 inches in diameter and that form a generally continuous canopy, or are spaced as appropriate for that species or species assemblage. Groves are generally non-linear. Other trees and understory vegetation located within the grove are considered part of the grove and are counted as part of the canopy area. A tree grove may be identified by a qualified professional, such as an arborist or environmental scientist, based on the types, configuration, or functions of a grouping of trees. Functions include structural support and wind protection for the trees within the grove, microclimate and shade, and habitat such as nesting, foraging, and cover for birds and other wildlife.

Tree Types

- **Dangerous Tree** is one where the condition of the tree presents a foreseeable danger of inflicting damage that cannot be alleviated by treatment or pruning. A tree may be dangerous because it is likely to injure people or damage vehicles, structures, or development, such as sidewalks or utilities.
- **Dead Tree** is a tree that is dead or has been damaged beyond repair or where not enough live tissue, green leaves, limbs, or branches exist to sustain life as determined by an arborist.
- **Dying Tree** is a tree in an advanced state of decline because it is diseased, infested by insects or rotting and cannot be saved by reasonable treatment or pruning, or must be removed to prevent spread of the infestation or disease to other trees or is imminently likely to become a danger or die.
- **Heritage Tree.** Trees designated as Historic Landmark Trees, Historic Trees, and Heritage Trees by the City of Portland.
- **Non-Native Non-Nuisance Tree.** A tree that is not identified as either a native tree species or a nuisance tree species in the *Portland Plant List*.

Triplex. See Residential Structure Types.

Truck. See Vehicle Types.

Underground Parking. Structured parking that does not qualify as floor area. See Structured Parking, Gross Building Area, and Floor Area.

Uplands. Lands not characterized by the presence of riparian areas, water bodies, or wetlands.

Utilities. Infrastructure services, including those in the Basic Utility Use Category, and structures necessary to deliver those services. These services may be provided by a public or a private agency. Examples include water, sanitary sewer, electricity, natural gas, and telephone.

For the purposes of the 600s series of chapters, utilities are telephone, cable, natural gas, electric, and telecommunication facilities.

Utility Scale Energy Production. Energy production that does not meet the definition of Small Scale Energy Production.

Utility Trailer. See Vehicle Types.

Valet Parking. Parking arrangement in which drivers leave and reclaim their cars at a destination site, with the cars parked at an off-site location by employees associated with the destination site. The valet parking occurs at the off-site location where the cars are parked.

Vegetation. All types of vegetation, including trees, shrubs, forbs, grasses, and other plants.

Vegetative Maintenance. Control of vegetation that encroaches or grows into public pathways or public drainageways and where maintenance is required for public safety. The control methods may include vegetation trimming or removal.

Vehicle Areas. All the area on a site where vehicles may circulate or park including parking areas, driveways, drive-through lanes, and loading areas. See also, Driveway and Parking Area.

Vehicle Types.

- **Motor Vehicle.** Vehicles that have their own motive power and that are used for the transportation of people or goods on streets. Motor vehicle includes motorcycles, passenger

vehicles, trucks, and recreational vehicles with motive power. See also Passenger Vehicle, Recreational Vehicle, and Truck.

- **Passenger Vehicle.** A motor vehicle designed to carry ten persons or less including the driver. Passenger vehicle also includes motor vehicles designed to carry ten persons or less that are constructed either on a truck chassis or with special features for occasional off-road use. Passenger vehicle includes vehicles commonly called cars, minivans, passenger vans, and jeeps. Passenger vehicle is intended to cover the vehicles defined as passenger cars and multipurpose passenger vehicles by the National Highway Traffic Safety Administration in Title 49 of the Code of Federal Regulations, Chapter V, Section 571.3. See also Recreational Vehicle, and Truck.
- **Recreational Vehicle.** A vehicle with or without motive power, which is designed for sport or recreational use, or which is designed for human occupancy on an intermittent basis. Recreational vehicle is divided into two categories as follows:
 - **Accessory recreational vehicle.** Accessory recreational vehicle includes nonmotorized vehicles designed for human occupancy on an intermittent basis such as travel trailers, park model recreational vehicles, campers, and fifth-wheel trailers. A camper is considered an accessory recreational vehicle when it is standing alone. Accessory recreational vehicle also includes vehicles designed for off-road use, such as off-road vehicles, dune buggies, and recreational boats.
 - **Motor home.** Motor home includes motorized vehicles designed for human occupancy on an intermittent basis. A camper is considered a motor home when it is on the back of a pick-up or truck. Motor homes are regulated as trucks unless the regulations specifically indicate otherwise. See also Truck.
- **Truck.** A motor vehicle which is designed primarily for the movement of property or special purpose equipment, or a motor vehicle that is designed to carry more than ten persons. Truck includes vehicles commonly called trucks, pick-ups, delivery vans, buses, motor homes and other similar vehicles. Truck is intended to cover the vehicles defined as trucks and buses by the National Highway Traffic Safety Administration in Title 49 of the Code of Federal Regulations, Chapter V, Section 571.3. Trucks are divided into three categories by size as stated below. See also Passenger Vehicle, and Recreational Vehicle.
 - **Light Truck.** Light trucks are trucks and similar vehicles with single rear axles and single rear wheels.
 - **Medium Truck.** Medium trucks are trucks and similar vehicles, other than truck tractors, with single rear axles and dual rear wheels. Truck tractors are in the Heavy Truck category.
 - **Heavy Truck.** Heavy trucks are trucks, including truck tractors, and similar vehicles with two or more rear axles.
- **Utility Trailer.** A vehicle designed to be pulled by a motor vehicle which is used to carry property, trash, or special equipment and that is 16 feet or less in length. Boat trailers are included as utility trailers. Utility trailers that are longer than 16 feet in length are considered industrial vehicles and are regulated as heavy trucks.

View Corridor. A view corridor is a three-dimensional area extending out from a viewpoint. The width of the view corridor depends on the focus of the view. The focus of the view may be a single object, such as Mt. Hood, which would result in a narrow corridor, or a group of objects, such as the downtown skyline, which would result in a wide corridor. Panoramic views have very wide corridors

and may include a 360-degree perspective. Although the view corridor extends from the viewpoint to the focus of the view, the mapped portion of the corridor extends from the viewpoint and is based on the area where base zone heights must be limited in order to protect the view. See also, Scenic Corridor.

Viewing Area. Part of a site developed for educational or public viewing purposes. The viewing area may be hard surfaced or decking, or within a structure such as a duck blind.

Waste Collection Areas. Waste collection areas include areas set aside or designed to be used for garbage collection and collection of materials for recycling. Waste collection areas include areas occupied by dumpsters and other solid waste receptacles.

Water Bodies. Permanently or temporarily flooded lands which may lie below the deepwater boundary of wetlands. Water depth is such that water, and not the air, is the principal medium in which prevalent organisms live, whether or not they are attached to the bottom. The bottom may sometimes be considered nonsoil or the water may be too deep or otherwise unable to support emergent vegetation. Water bodies include rivers, streams, creeks, sloughs, drainageways, lakes, and ponds. See also Identified Waterbodies.

Water Quality Resource Area. The water quality resource area is a vegetated corridor and the adjacent protected water feature. The functional values of the water quality resource area include: providing a vegetated corridor to separate protected water features from development; maintaining or reducing stream temperatures; maintaining natural stream corridors; minimizing erosion, nutrient and pollutant loading into water; filtering, infiltration and natural water purification; and stabilizing slopes to prevent landslides contributing to sedimentation of water features.

Wetland. An area that is inundated or saturated by surface or ground water at a frequency and duration sufficient to support, and that under normal circumstances does support, a prevalence of vegetation typically adapted for life in saturated soil conditions. Wetlands include swamps, marshes, bogs, and similar areas. See also Identified Wetlands.

Wildlife Species of Concern. Wildlife species of concern are those species with a large enough body mass (i.e. raptors, waterfowl, coyote, great blue heron or species with flocking behavior (i.e. European starling, gulls) that can result in a high probability of severe impact with aircraft. The wildlife species of concern list is in the Port of Portland's Wildlife Hazard Management Plan, as authorized by the Federal Aviation Administration.

Wind Turbine or Wind Energy Turbine. A wind turbine or wind energy turbine converts kinetic wind energy into rotational energy that drives an electrical generator. A wind turbine typically consists of a mast or mounting frame and structural supports, electrical generator, transformer, energy storage equipment, and a rotor with one or more blades. Some turbines use a vertical axis/helix instead of rotor blades.

- Small Wind Turbines or Small Wind Energy Turbines are turbines with an American Wind Energy Association (AWEA) rated power output of 10 kW or less. They also are certified by the Small Wind Certification Council to meet the American Wind Energy Associations (AWEA) Small Wind Turbine Performance and Safety Standards. These turbines may or may not be connected to the power grid.
- Large Wind Turbines or Large Wind Energy Turbines are turbines with a rated power output of more than 10kW and up to 300 kW. These turbines may or may not be connected to the power grid.

(Amended by: Ord. No. 163957, effective 4/12/91; Ord. No. 164899, effective 12/11/91; Ord. No. 165417, effective 6/5/92; Ord. No. 165681, effective 7/15/92; Ord. No. 166313, effective 4/9/93; Ord. No. 166702, effective 7/30/93; Ord. No. 167054, effective 10/25/93; Ord. No. 167127, effective 12/17/93; Ord. No. 167186, effective 12/31/93; Ord. No. 167189, effective 1/14/94; Ord. No. 167293, effective 1/19/94; Ord. No. 168698, effective 4/17/95; Ord. No. 169535, effective 1/8/96; Ord. No. 169763, effective 3/25/96; Ord. No. 169987, effective 7/1/96; Ord. No. 170248, effective 9/17/96; Ord. No. 170704, effective 1/1/97; Ord. No. 171219, effective 7/1/97; Ord. No. 171740, effective 11/14/97; Ord. No. 171718, effective 11/29/97; Ord. No. 171879, effective 2/2/98; Ord. No. 172882, effective 11/18/98; Ord. No. 173015, effective 2/12/99; Ord. 173528, effective 7/30/99; Ord. No. 174263, effective 4/15/00; Ord. No. 174378, effective 5/26/00; Ord. No. 175204, effective 3/1/01; Ord. Nos. 175341 and 175358, effective 3/16/01; Ord. No. 175837, effective 9/7/01; Ord. No. 175877, effective 9/21/01; Ord. No. 175966, effective 10/26/01; Ord. No. 176351, effective 3/27/02; Ord. No. 176443, effective 5/30/02; Ord. Nos. 175965 and 176333, effective 7/1/02; Ord. No. 176469, effective 7/1/02; Ord. No. 176587, effective 7/20/02; Ord. No. 177028, effective 12/14/02; Ord. No. 177082, effective 1/20/03; Ord. No. 177422, effective 6/7/03; Ord. No. 177701, effective 8/30/03; Ord. No. 178020, effective 12/20/03; Ord. No. 178172, effective 3/5/04; Ord. No. 178509, effective 7/16/04; Ord. No. 178657, effective 9/3/04; Ord. No. 179092, effective 4/1/05; Ord. No. 179540, effective 9/26/05; Ord. No. 179845, effective 1/20/06; Ord. No. 179925, effective 3/17/06; Ord. Nos. 179980 and 179994, effective 4/22/06; Ord. No. 180619, effective 12/22/06; Ord. No. 181357, effective 11/9/07; Ord. No. 182429, effective 1/16/09; Ord. No. 183269, effective 10/1/09; Ord. No. 183598, effective 4/24/10; Ord. No. 183750, effective 6/4/10; Ord. No. 184016, effective 08/20/10; Ord. No. 184235, effective 11/26/10; Ord. No. 184521, effective 5/13/11; Ord. No. 184524, effective 7/1/11; Ord. No. 185412, effective 6/13/12; Ord. No. 815915, effective 5/1/13; Ord. No. 186639, effective 7/11/14; Ord. No. 186736, effective 8/29/14; Ord. No. 186053, effective 1/1/15; Ord. No. 187216, effective 7/24/15; Ord. No. 187471, effective 1/1/16; Ord. No. 188077, effective 12/9/16; Ord. No. 188142, effective 1/13/17; Ord. No. 188259, effective 3/31/17; Ord. No. 188177, effective 5/24/18; Ord. No. 188958, effective 5/24/18; Ord. No. 189000, effective 7/9/18; Ord. No. 189807, effective 12/18/19; Ord. No. 189805, effective 3/1/20; Ord. No. 190023, effective 8/10/20 and 8/1/21; Ord. No. 190093, effective 9/11/20 and 8/1/21; Ord. No. 190241, effective 3/1/21; Ord. No. 190380, effective 4/30/21 and 8/1/21; Ord. No. 190687, effective 3/1/22; Ord. No. 190851, effective 6/30/22; Ord. No. 190978, effective 8/31/22; Ord. No. 190834, effective 10/1/22; Ord. No. 191164, effective 3/31/23; Ord. No. 191310, effective 6/30/23; Ord. No. 191477, effective 3/1/24.)