

SECTION A-A

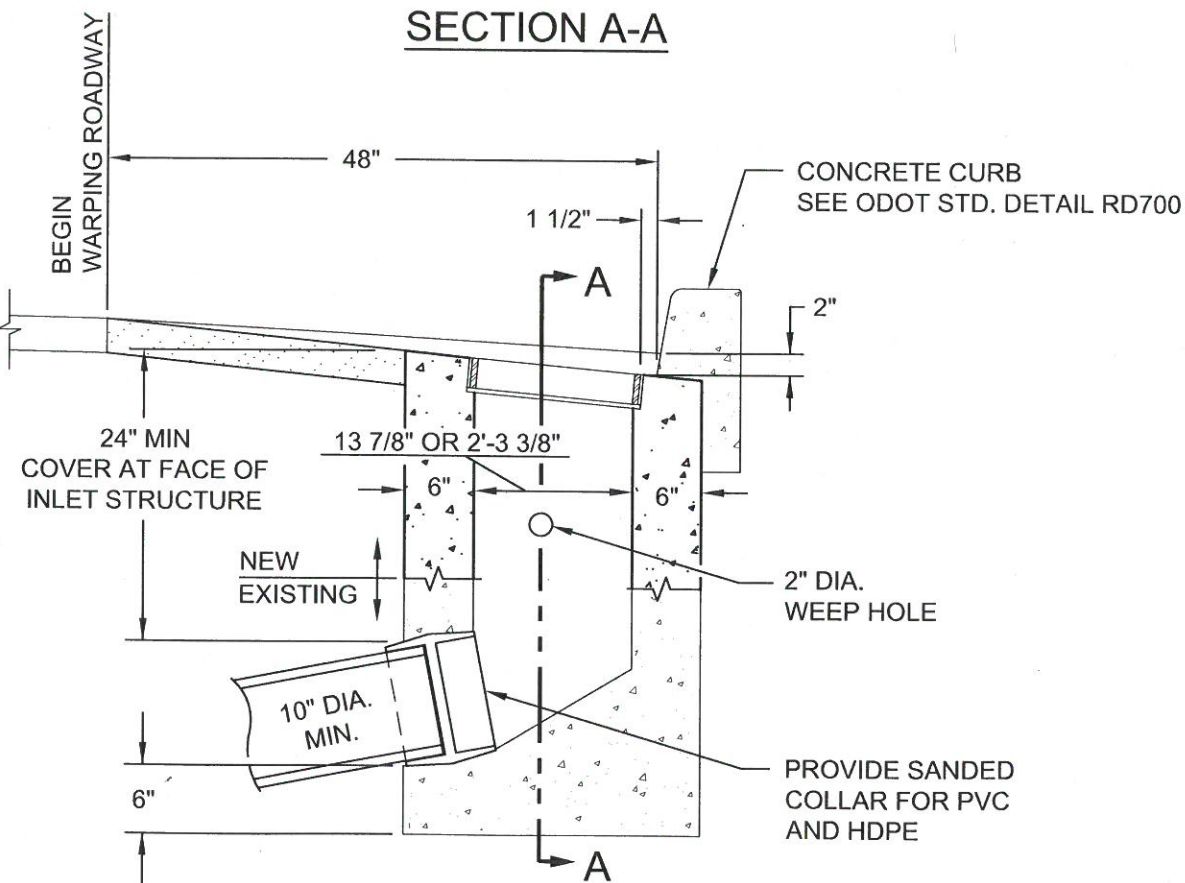

SIDE VIEW

NOTES:

1. DEMOLISH TOP 6-12 INCHES OF THE EXISTING INLET. ROUGHEN AND PREPARE SURFACE FOR BONDING NEW CONCRETE TO EXISTING CONCRETE.
2. DEPRESS GRATE 2 INCHES BELOW LONGITUDINAL GUTTER SLOPE AT INLET. WARP GUTTER TO MEET NORMAL GUTTER SLOPE AND ROADWAY CROSS SLOPE, AS SHOWN.
3. MAXIMUM INLET DEPTH 4 FEET.
4. CONCRETE SHALL BE COMMERCIAL GRADE.
5. OUTLET PIPE SHALL HAVE A FLEXIBLE JOINT WITHIN 18 INCHES OF INLET STRUCTURE.
6. CONSTRUCT OUTLET PIPE WITH A WATERTIGHT SEAL AND CONNECTION.
7. THE OWNER'S REPRESENTATIVE MUST APPROVE ANY SUBSTITUTION OF THIS STANDARD.
8. WHEN COVER DEPTH IS LESS THAN 24 INCHES, USE PVC C-900 CLASS 235 UNLESS PIPE OTHERWISE APPROVED.
9. WHEN DIRECTED, SALVAGE AND REUSE THE EXISTING GRATE.

The selection and use of this Standard Detail, while designed in accordance with generally accepted engineering principles and practices, is the sole responsibility of the user.



Bureau of Environmental Services
CITY OF PORTLAND, OREGON

Walter J. ...
Chief Engineer

Standard Detail Title

Adjust Concrete Inlet

Note:
All material and workmanship shall be in accordance with the City of Portland Standard Construction Specifications.

Effective Date: 11-17-15

Calc. Book No.: N/A

Baseline Report Date: N/A

Standard Detail No.

P-201