

TOP VIEW

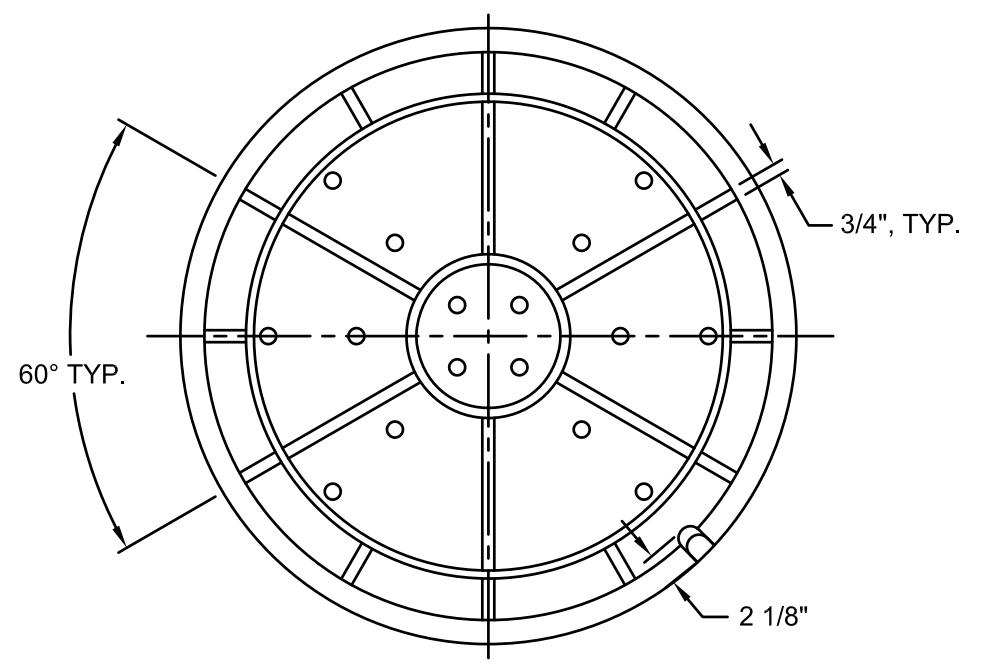

BOTTOM VIEW

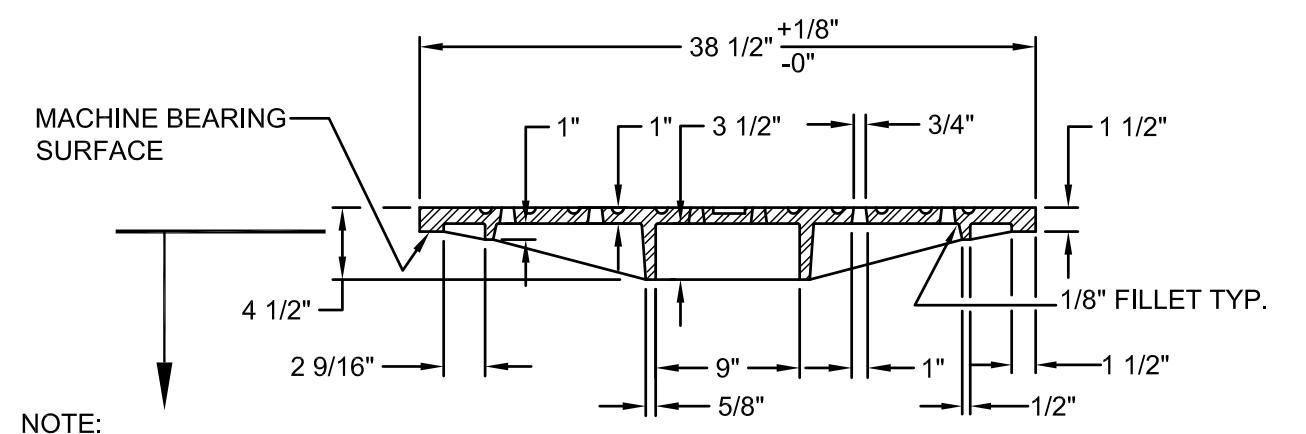

NOTE:
FOUNDRY MAY VARY
UNDERSTRUCTURE
DESIGN AND DIMENSIONS SUBJECT
TO APPROVAL OF DESIGN AND
TESTING BY BES.

SECTION A-A

NOTES:

1. EACH CASTING SHALL BE STAMPED WITH MANUFACTURE'S INITIALS, HEAT NUMBER, AND YEAR OF THE CAST.
2. TOLERANCE ON NON-MACHINED SURFACES TO BE ± 1/16".
3. APPROX. WT. = 330 LBS. MATERIAL TO BE DUCTILE IRON, ASTM A536, GRADE 80-55-06.

P-177_36-INCH_MH_COVER.DWG 8/20/20 12:59 PM RICKS

The selection and use of this Standard Detail, while designed in accordance with generally accepted engineering principles and practices, is the sole responsibility of the user.	 Bureau of Environmental Services CITY OF PORTLAND, OREGON _____ Chief Engineer	
	Standard Detail Title	
	36 Inch Maintenance Hole Cover	
Note: All material and workmanship shall be in accordance with the City of Portland Standard Construction Specifications.	Effective Date: 01-01-09	Standard Detail No. P-177
	Calc. Book No.: N/A	
	Baseline Report Date: N/A	